

Maintenance Instructions for: **RIS-STOP-FLOAT-KIT** For RIS-STOP OVERFILL PREVENTION VALVES

(Instructions for flanged & threaded float assemblies)



**ALWAYS USE
NON-SPARK TOOLS!**

PLEASE READ CAREFULLY BEFORE SERVICING

ALWAYS USE NON-SPARK TOOLS!

ALWAYS USE NON-SPARK TOOLS!

Introduction

The RIS-STOP Range of Overfill Prevention valves are Normally Closed, Failsafe and Testable mechanical tank overfill prevention devices. Dependent on the model they are suitable for pressure and gravity fill deliveries to above and below ground fuel storage tanks. The valves are designed and manufactured for use with Petroleum Spirit and Diesel, including Bio-Fuel Blends.

NB: If use with alternative fuels outside this spectrum is required please refer to Risbridger Ltd.

The RIS-STOP valves are opened by the flow of product being delivered into the tank, and closed against the delivery flow when the float lifts at the preset maximum tank capacity (Normally 95% of Tank Capacity. For details of Installing RIS-STOP Valves please see relevant Installation Instructions.)

Should the float become dislodged or damaged the valve will fail to open to receive fuel into the tank, this indicates a problem with the valve and is it's FAILSAFE mode.

Maintenance is recommended to be carried out on a 12 month period. Testing of the Valve's correct functioning is part of this Maintenance Procedure and is carried out during a delivery, when tank is at least 80% full. Further Testing Operations can be carried out to the owner's or operator's required schedules.

Before starting a Servicing, Maintenance or Testing Operation please make sure you observe the correct Health & Safety Precautions and carry out work with due adherence to Site Specific Regulations

Before starting work ensure you have the following: -

Recommended Installation Tools required for fitting RIS-STOP-FLOAT-KIT(-F)



- Spanners 13mm, 1 inch AF x2, adjustable up to 2.5 inch
- Metric sockets 13mm,
- Torque wrench
- Thread / O-ring Grease

ALWAYS USE NON-SPARK TOOLS!

IN THE BOX

Service kit includes:

- "O"-Ring
- Sensor Valve Seal
- Flame Arrester
- 2" Flange Gasket – (Cork) *Applicable to Flanged Float Kit only.*

FOR USE ON...

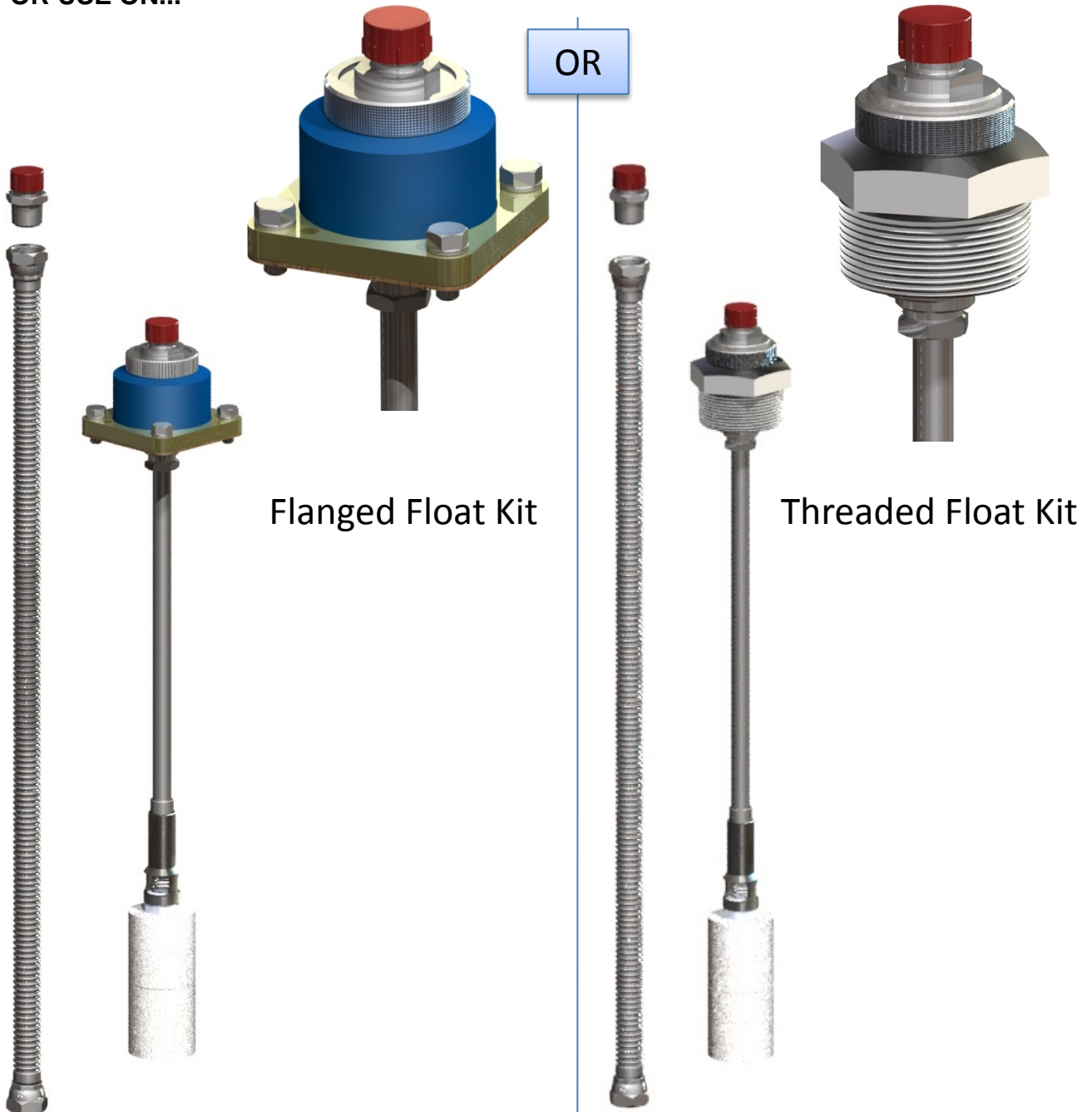

Flanged Float Kit

Threaded Float Kit

ALWAYS USE NON-SPARK TOOLS!

Service Instructions For Threaded & Flanged Float Kits Removal of RIS-STOP-FLOAT-KIT from Tank Lid:

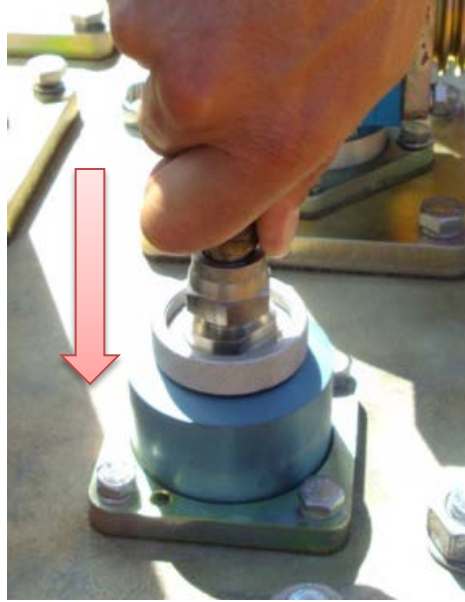

1. Release any pressure remaining in the float assembly by unscrewing the sensor lock ring and depressing into the float body. Any excess pressure will release into the tank ullage space.

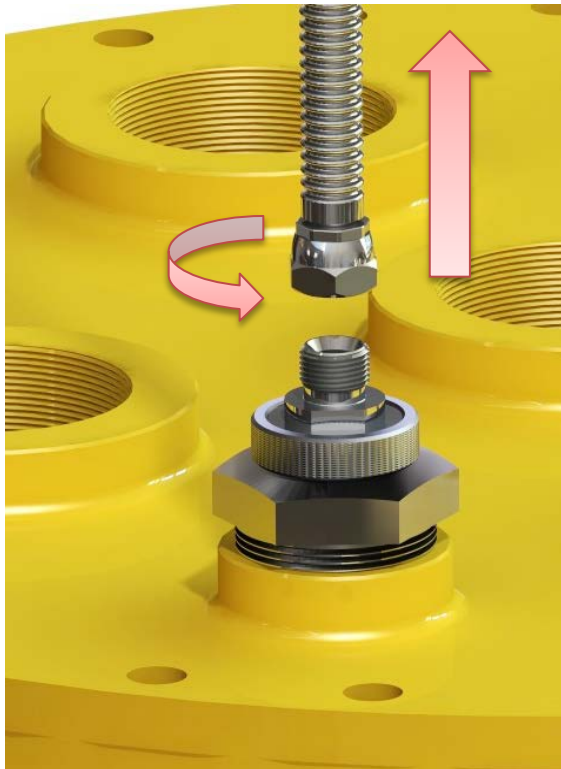

2. Remove flexi hose from float body and fit the red cap supplied to protect threads and prevent ingress of dirt.



ALWAYS USE NON-SPARK TOOLS!



3. Using a large non-spark adjustable spanner (2.5 inch), unscrew the float and remove. Take care not to damage the float tube or foam float assembly.

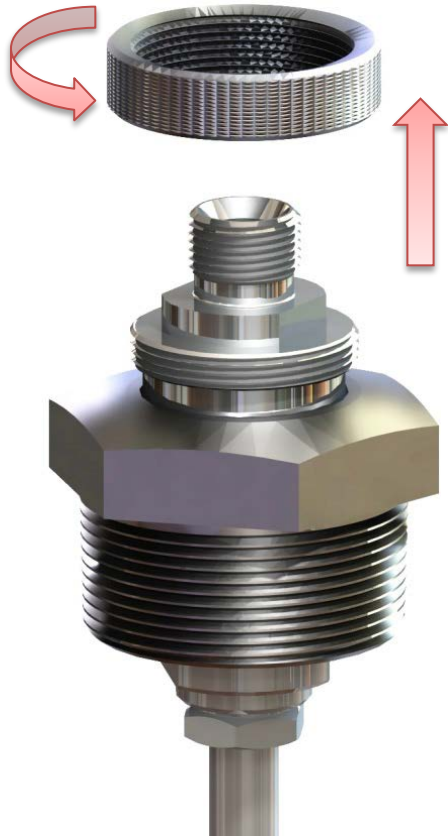
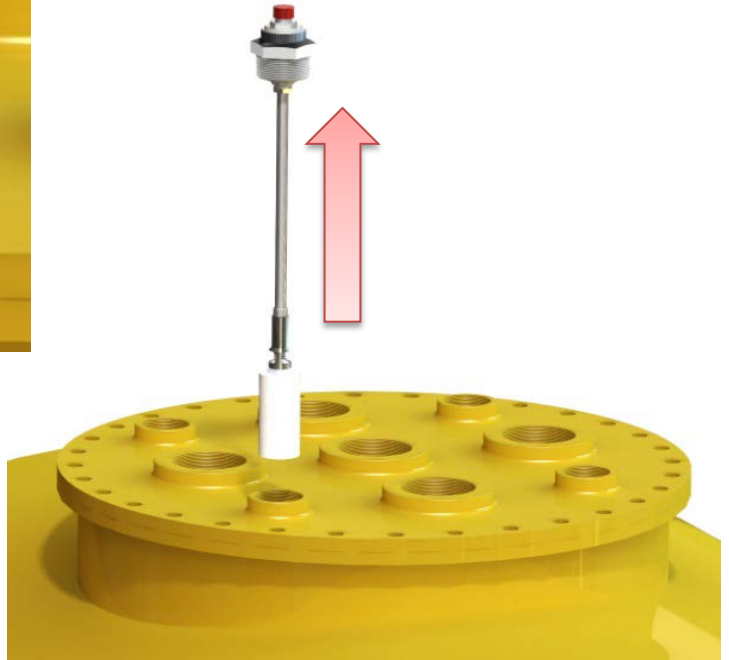

N.B. ONCE REMOVED FROM THE TANK LID, CONTINUE WORK ON THE FLOAT, IN A SAFE AREA TO AVOID UNNECESSARY POTENTIAL SPARKS!

4. Remove sensor locking ring from the float assembly and retain in a clean area.

ALWAYS USE NON-SPARK TOOLS!

!!CAUTION - Sensor core & Sensor Body are sprung loaded!!

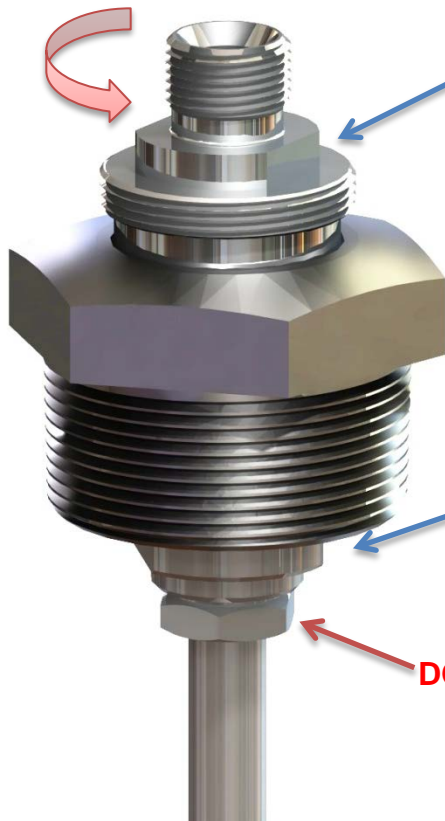

UPPER PORTION

5. Use an adjustable spanner to hold the sensor core and unscrew the upper portion of the sensor body with a 1" spanner (both dictated by large flats).

SENSOR CORE

DO NOT UNSCREW.

**TAKE CARE WHEN REMOVING
SO OLIVE FITMENT IS NOT
DAMAGED!!**

"O"-RING

FLAME ARRESTER



6. Exploded view shows "O"-ring, Flame arrester and Sensor valve seal locations. All the above need to be replaced prior to re-assembly. Please follow instructions on how to do this correctly.

SENSOR VALVE SEAL

ALWAYS USE NON-SPARK TOOLS!

Installation of RIS-STOP-FLOAT-SERVICEKIT:

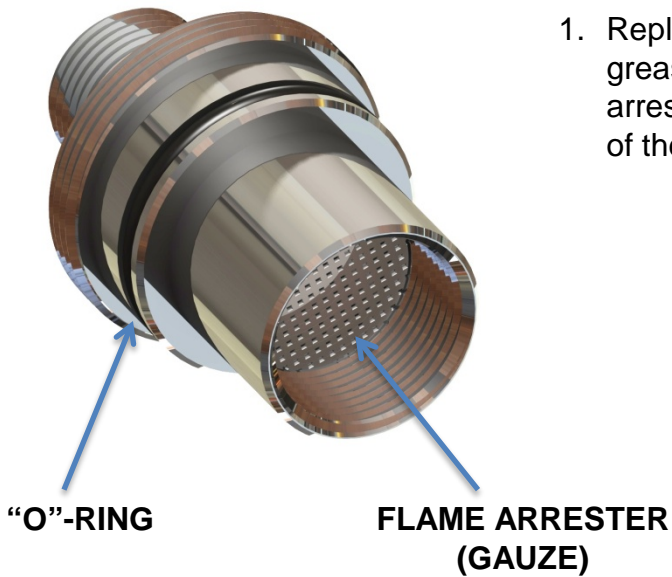

1. Replace "O"-ring (using "O"-ring grease) and install the flame arrester inside the upper portion of the sensor body.

2. Rest the upper portion of the sensor body on the spring and place within the sensor body.

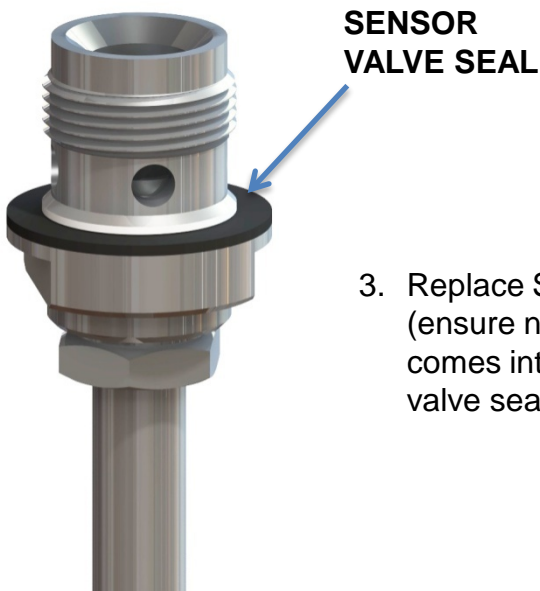
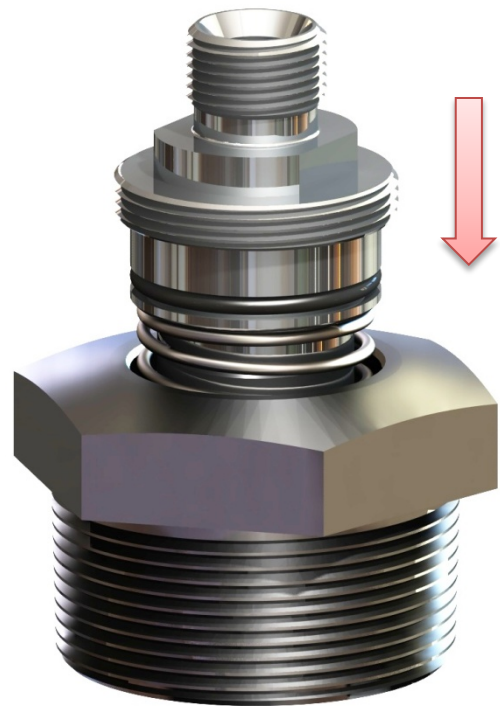

3. Replace Sensor Valve Seal (ensure no grease from "O"-ring comes into contact with the valve seal).

ALWAYS USE NON-SPARK TOOLS!

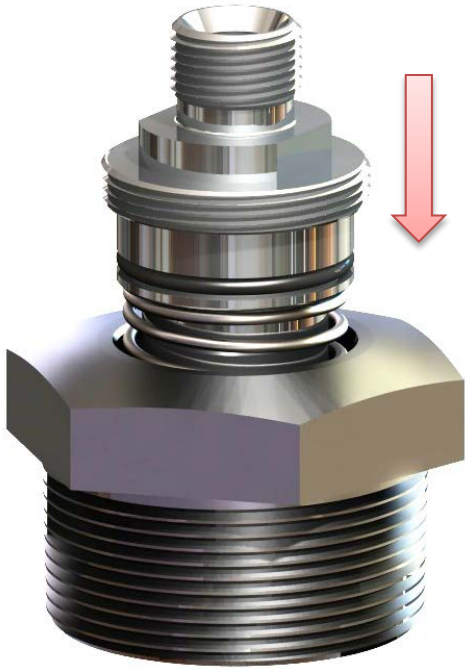

4. Compress the upper portion in the valve body and screw the core together which will engage the upper portion (locking the valve together).

Using an adjustable and 1" spanner tighten until firmly locked together.

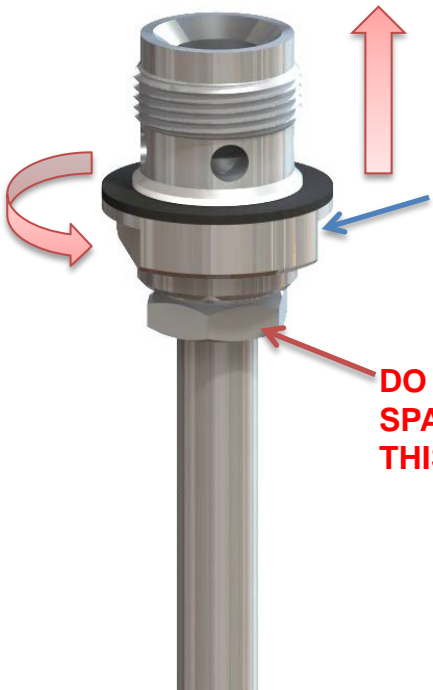

**USE THESE
FLATS TO
TIGHTEN**

**DO NOT PLACE
SPANNER ON
THIS NUT**



ALWAYS USE NON-SPARK TOOLS!

5. Make sure the tube is still tight on the olive by checking the tightness of the bottom nut in the valve sensor body:



ENSURE THESE 2 PARTS ARE LOCKED FIRMLY TOGETHER

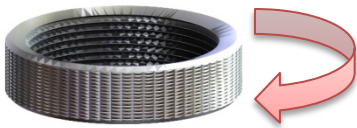

6. Re-fit sensor locking ring
Note: Tapered edge to engage thread first.

HAND TIGHT ONLY



ALWAYS USE NON-SPARK TOOLS!

!! TAKE CARE NOT TO DAMAGE THE FLOAT ACTIVATION ASSEMBLY !!

7. Prior to Re-Fit of the Float Assembly onto the tank lid it is important that the operation of the activation valve is checked to ensure it is smooth and unhindered from contamination.

CLEAR WITH AN AIR LINE AND APPLY WD40 OR "3 in 1" **AEROSOL** SPRAY LUBRICATION TO ENSURE FREE MOVEMENT.

DO NOT USE ANY OILS OR GREASE AS THIS MAY RESULT IN STICKING OF THE VALVE.

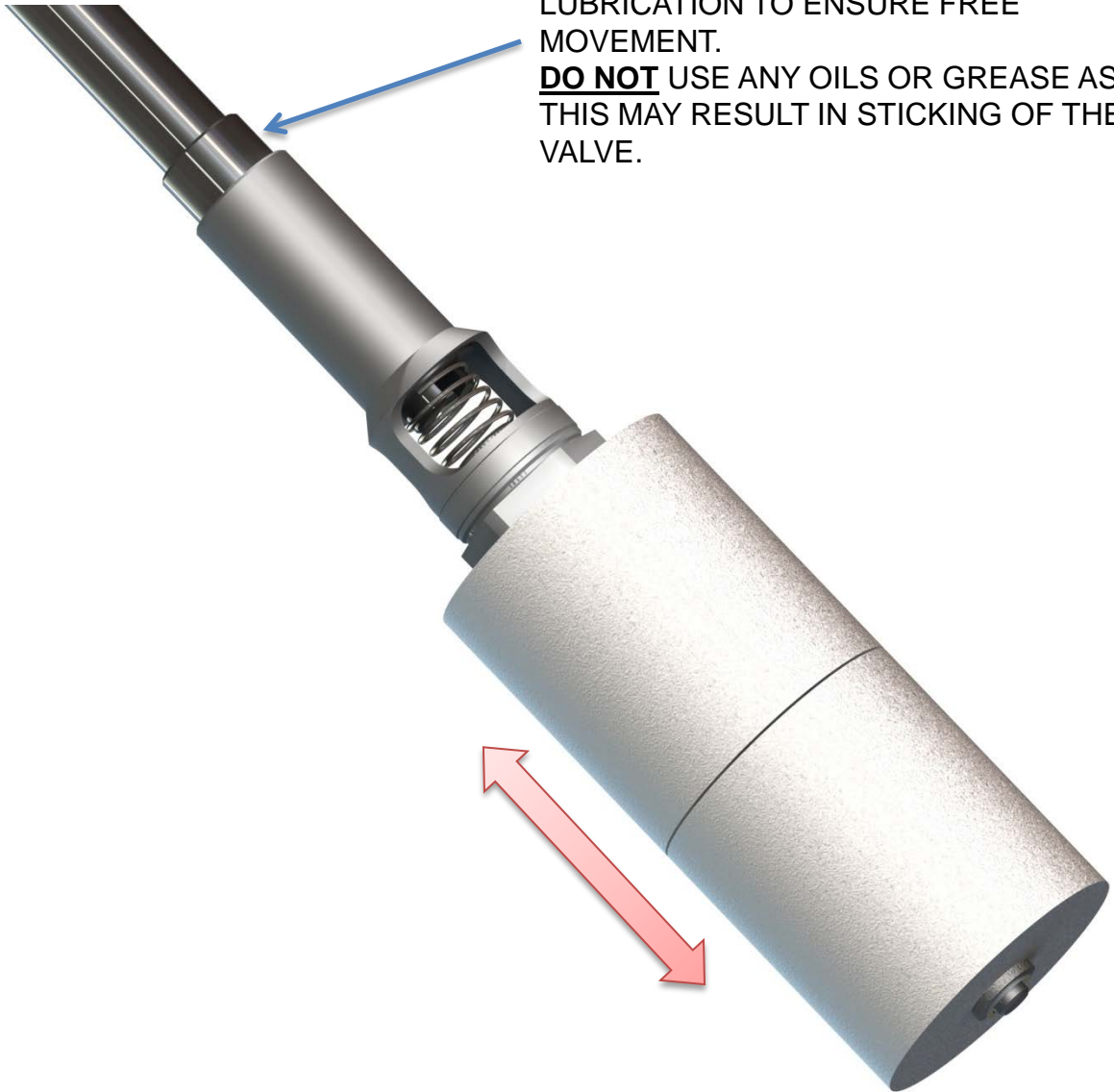

ALWAYS USE NON-SPARK TOOLS!

!! TAKE CARE NOT TO DAMAGE THE FLOAT ACTIVATION ASSEMBLY !!

8. Repeat step 7 to ensure the sealing face of the valve is free from contamination and the operation is smooth and unhindered.

CLEAR WITH AN AIR LINE AND APPLY WD40 OR "3 in 1" **AEROSOL** SPRAY LUBRICATION TO ENSURE FREE MOVEMENT.

DO NOT USE ANY OILS OR GREASE AS THIS MAY RESULT IN STICKING OF THE VALVE.

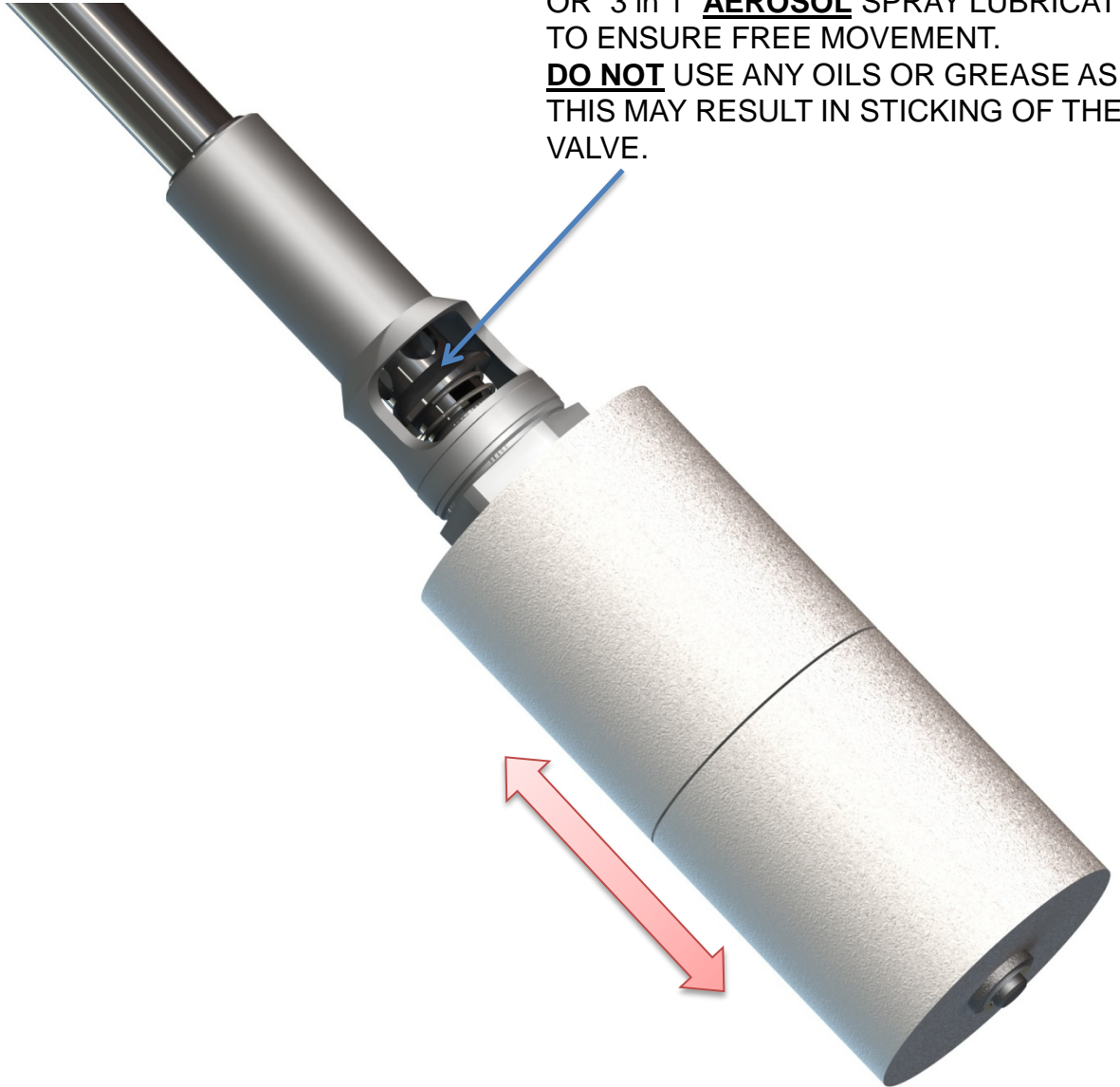

ALWAYS USE NON-SPARK TOOLS!

RIS-STOP-FLOAT-KIT 'THREADED' Installation (see next page for FLANGED VERSIONS)

PREPARATION

Old thread sealant on the float kit threads, should be thoroughly cleaned off prior to re-fitting the float.

Threaded sockets should be tested with a suitable male thread fitting to ensure there is no binding. Tight threads must be cleared with a thread tap of correct specification:

2in	BSPP Female	(ISO 228-G2)
-----	-------------	--------------

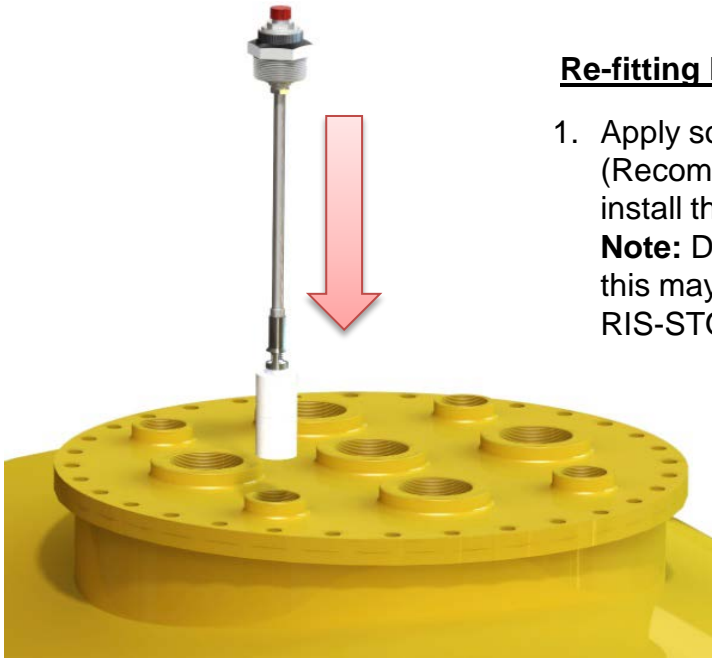

Re-fitting Instructions:

1. Apply soft setting thread sealant (Recommended to use Gasoila) and install the float into the tank lid.

Note: Do not damage the Float as this may result in malfunction of the RIS-STOP valve.

2. Tighten with appropriate spanner (2.5 inch), but take care not to over-tighten aluminium threads.
3. Check operation of the Sensor Valve by loosening the locking ring approximately 4 turns and depressing into the valve body.



ALWAYS USE NON-SPARK TOOLS!

RIS-STOP-FLOAT-KIT (Flanged) Installation.

The blind tapping's on the tank lid should be individually and thoroughly cleaned (compressed air if available). Use a dummy bolt to check for full thread engagement without binding. If required, tight threads should be cleared with a suitable thread tap, refer to bolt table.

Bolt Thread (Male Tap Size)	Recommended Torque Setting	Socket/Spanner Size
M8 x 1.25	20 Nm (15 lbf/ft)	13mm

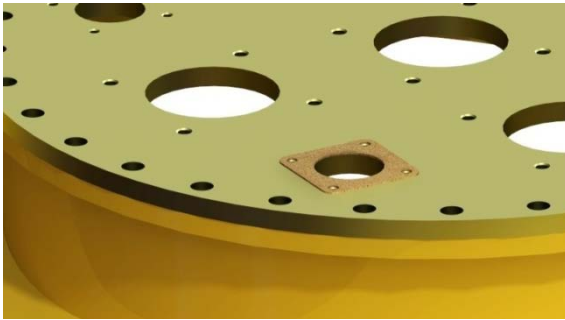

1. Ensure tank lid is free from grease and dirt, then fit new gasket over lid port (as supplied).

2. Install float assembly into the tank lid.
Note: Do not damage the Float during installation as this could result in malfunction of RIS-STOP valve.

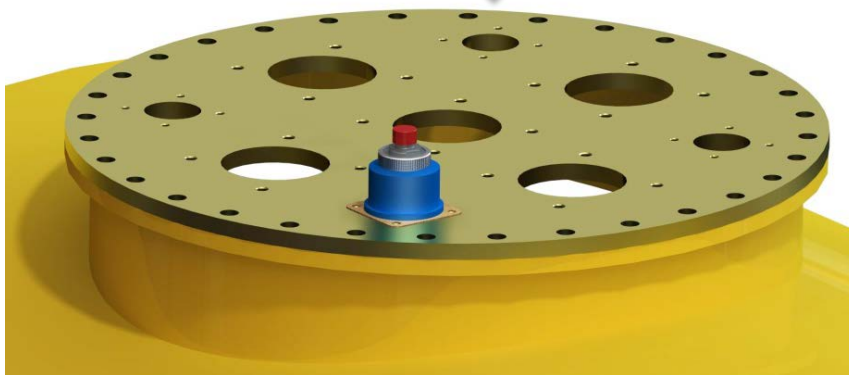
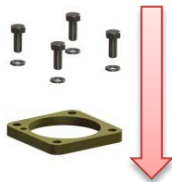
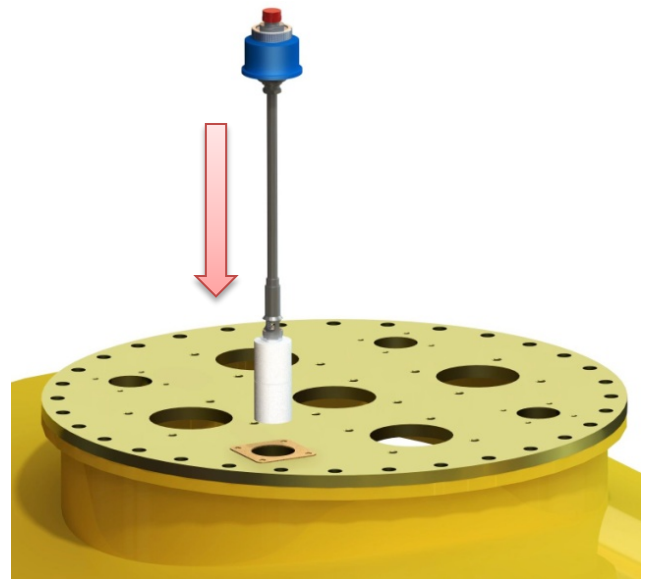

3. Secure the Float assembly in place using 2in flange plate and M8 bolts (M13 spanner/socket) with spring washers.
4. Check operation of the Valve by loosening the locking ring approximately 4 turns and depressing into the valve body.

ALWAYS USE NON-SPARK TOOLS!

RIS-STOP-FLOAT-KIT HOSE INSTALLATION. (BOTH VERSIONS)

1. Re-attach flexi hose to the float as shown with a 1" A/F spanner (or appropriate adjustable):

Note: Use a 1" A/F spanner (or appropriate adjustable) to hold the sensor core in place when installing the flexi hose.

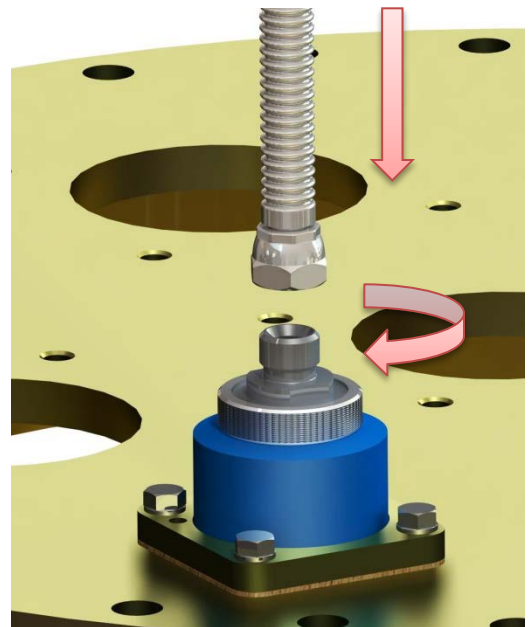
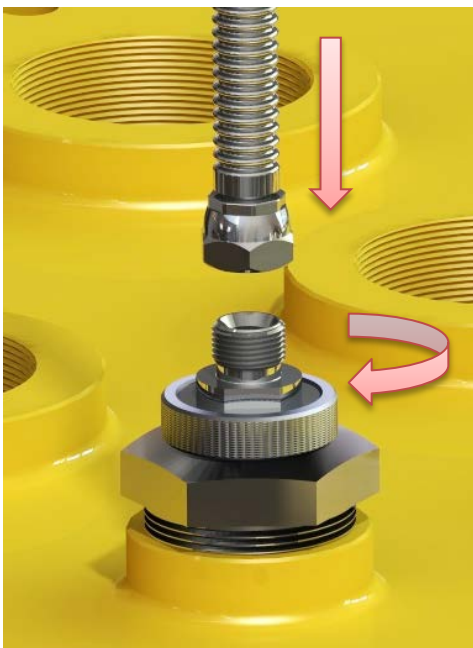

ALWAYS USE NON-SPARK TOOLS!

TESTING THE VALVE ON COMPLETION OVERFILL SIMULATION PROCEDURE:

The RIS-STOP overfill prevention devices can be safely tested during a delivery to check the integrity of the working parts. This is recommended to be carried out after installation before the site is commissioned OR at annual maintenance intervals.

1. The underground tank is required to be approximately 80% full to undertake testing.
2. Loosen the sensor lock ring by hand approximately 4 turns.

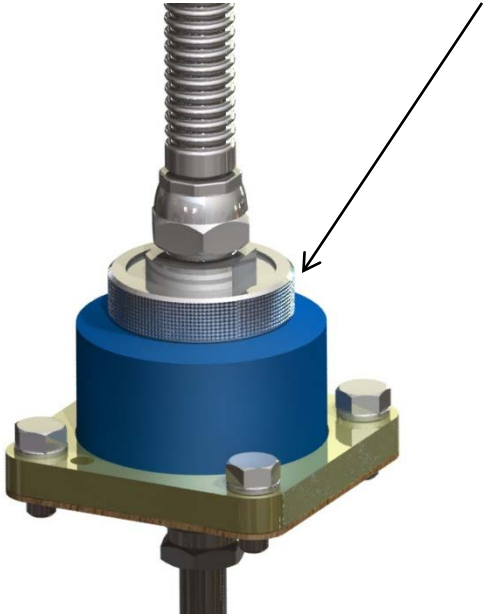

3. Part way through a normal tanker delivery (when tank is above 80% full), depress the test top of the sensor cartridge.



OVERFILL SIMULATION
↓



Whilst holding the top down a mild 'thump' and fill hose reaction should be noticed indicating that the shut off valve has closed.

ALWAYS USE NON-SPARK TOOLS!

4. Release the sensor test top (do not disconnect the tanker fill hose). After a few seconds the valve should re-set to the open position allowing normal delivery. If the overfill prevention device does not respond in this way contact the supplier for instructions.

5. **Re-tighten the sensor lock ring.**



IF A REAL OVERFILL OCCURS THE TANKER DELIVERY VALVE MUST BE CLOSED IMMEDIATELY.

Depending on the length of the pipe work, the leak down rate will take approx 8-10 minutes to drain down the hoses depending on the extent of the overfill.

ALL OVERFILL INCIDENTS SHOULD BE REPORTED AND INVESTIGATED.

ALWAYS USE NON-SPARK TOOLS!

ALWAYS USE NON-SPARK TOOLS!

FOR REFERENCE.

Risbridger Ltd offer a range of tools specifically designed for Risbridger products. For further details please contact Risbridger or alternatively, order direct from our website: www.risbridger.com

For installation details of the products supplied with a RIS-STOP Overfill prevention valve and for maintenance instructions, please see documents enclosed with the products or view on our website:

WARRANTY.

All RISBRIDGER Ltd products are guaranteed against defects in material and workmanship for a period of 12 months from the date of purchase subject to normal use and service. The sole obligation under this warranty is limited to repair or replacement, at the option of RISBRIDGER Ltd any product found to be defective upon examination provided that such product will be returned for inspection carriage paid, within three months of installation. Liability is strictly limited to replacement of defective parts manufactured by RISBRIDGER Ltd and no liability can be accepted for any loss or consequential damages arising from the installation or use of any products supplied by RISBRIDGER Ltd whatsoever the cause. This warranty shall not apply to any product subject to abuse, negligence, accident, misapplication or any alteration by others.

