

Risbridger

Design innovation

Sound engineering

Integrity

Quality

100
Years
of quality engineering



Risbridger designs and manufactures specialised engineering products, primarily for the international aircraft servicing and petrochemical industries.

Risbridger products help to protect and dispense fluids around the world, whether it is petroleum spirit, or oils and fluids for aviation, automotive or motorsport applications.



Contact

+44 (0) 1737 372 680

info@risbridger.com

www.risbridger.com

Follow Us



Risbridger Ltd

25 Trowers Way
Holmethorpe Ind Est
Redhill
Surrey
RH1 2LH
UK

MODULAR PVV VENT SYSTEM

LOW LEVEL

LOW
MAINTENANCE

LOW COST



Risbridger is pleased to introduce it's latest low level pressure vacuum valve system designed specifically as a modular low cost, low maintenance solution to vent stack issues.

- **No more working at height during routine maintenance on your forecourt.**
- **ATEX approved labyrinth design raincap drastically reduces the risk of water ingress into your fuel tanks.**
- **Solid connections eliminate the issues with flexible joint vent systems during severe weather conditions.**
- **Tailor the functionality of the system to your needs or budget.**

The DEAD-STOP is a 2" overfill prevention valve with a ZERO leak rate, suitable for commercial above ground diesel storage installations, generator belly tanks and pressure deliveries.

With a flow rate of 10 – 500 l/min and a maximum operating pressure of 10 bar (145 psi) the DEAD-STOP is suitable for a range of applications, protecting against the risk of an overfill should other methods fail.

UK Patent No: GB2582354



A high-quality overfill prevention valve with Zero leak rate.

Suitable for commercial above ground storage tank installation and pressure deliveries, incorporating many proven features from our RIS-STOP range.

- Cartridge construction for easy installation and in-situ examination via a single 2" aperture.
- High flow capacity
- Effective at low flow rates (10 – 500 l/m) pressure delivery up to 10 bar maximum.
- Compatible with all pipework brands
- Flexible connectors are available, to make installation easy and remove stress from pipework, which can distort the valve and prevent it from operating correctly
- The valve shuts in the direction of the flow, ensuring a positive seal maintained by the fill pressure
- 100% tested in factory

Materials:

Anodised aluminium
Viton A (FKM)
Stainless steel
Polyacetal
Nitrile rubber bonded cork
HDPE closed cell foam

Suitable for:

Diesel
Bio-Diesel
FAME Blends
Waste Oil

Document Ref:

DATA-DEAD-STOP-231108

Installation Instructions

INS-DEAD-STOP

Maintenance Instructions

MAINT-DEAD-STOP

An innovative and very cost effective new 2" Anti-Syphon Valve brings better flow and performance to above ground storage tank applications.

- High flow rate from 12 litres up to 180 litres/minute
- Suitable for head pressures of 6.5m (0.6 bar)
- Can be adapted to 1.5 inch pipework
- 2 inch peccat 4 bolt flange allows for easy fitting
- Includes stainless steel inlet screen
- Installed at tank base to replace elbow fittings
- Hydraulic valve damper and progressive flow opening minimise 'hunting'



Pt No. RIS-ASV

The Risbridger Anti-Syphon Valve meets the requirements of standard and high-flow fuel dispensers connected to above ground storage tanks with 50mm (2 inch) pipework. Providing anti-syphon protection, the valve is capable of flow rates of up to 180 litres per minute. The diaphragm servo assisted operating method allows high flow and low vacuum pressure loading of the dispenser pump - unlike spring resistance type designs. Hydraulic valve damper and progressive flow opening minimise 'hunting' flow modulation problems over a wide flow and head pressure range.

RESTRICTION OF USE.

The RIS-ASV is designed to open under vacuum and so should not be installed on systems where the delivery pump air separator outlet is below the level of the ASV as this may cause the valve to open.

Patent applied for: 1606281.2

Materials: Anodised aluminium Viton
Stainless steel
Delrin

Suitable for:
Petrol
Diesel (including bio-fuel blends)
AvGas

Head pressures up to 6.5m
(0.6 bar)

Document Ref:
DATA-RIS-ASV-170809
Related Documents
INS-RIS-ASV

Specifications:

Max Operating Pressure: +10.0 bar
Operating Flow Range: 0 l/min to 50 l/min Internal
Non Return Valve: Opens at 20 mbar Break Forces:
Note requires both halves to be rigidly mounted
Tensile: 22.5 RN
Shear: 14.7 RN
Bending Moment: 415 Nm
Operating Temperature Range: -20 deg C to
+40 deg C
Fluid Contact Material: All stainless steel



Pt No. RIS-SHEAR-ADBLUE-MK2

Optional Under Pump Valve for quick and easy access to isolate or test the line (shown below):

• **RIS-UPV-TEST-SS** Stainless Steel Under Pump Valve.

• **TF10MSS 1"** Stainless Steel Under Pump Valve Flange.



RIS-SHEAR-ADBLUE valves prevent leakage of Adblue product onto the forecourt when the dispenser is knocked over or impacted. The **INTEGRAL one-way valve** helps retain line prime. **OPTIONAL Under Pump Valves** allows isolation and line testing.

- Full flow low pressure drop design
- Design allows full shut-off with minimal bending or shear movement
- Seals upstream and downstream on impact
- Tested shut-off activation force = 415 Nm bending moment
- Cylindrical body fits through and allows sealing with standard membrane seals
- Includes brackets, bolts and instructions
- **OPTIONAL** stainless steel under pump valve, for quick and easy isolation/line testing above and below the shear valve.

Materials:

Viton A (FKM)
Stainless Steel
Anodised Aluminium Clamps

Suitable for:

Adblue product lines

Fittings:

Male 1" BSP(T) / Female 1"
BSP(P) dependent on model

Document Ref:

DATA-RIS-SHEAR-ADBLUE-MK2-161101

Related Documents:

MAINT-RIS-SHEAR-ADBLUE

Patented design (UK:GB2342709, US:
6,802,332, EU: EP1,222,423,B1)

Specifications:

Operating pressures:

-5 mbar - +35 mbar

Operating flow range: 0 l/m - 150 l/m

Isolator valve opens: 20 mbar

Break forces: *

Tensile - 3920 N (400 kgF)

Shear - 3920 N (400 kgF)

Bending moment - 50 Nm

* If upper and lower halves are rigidly mounted

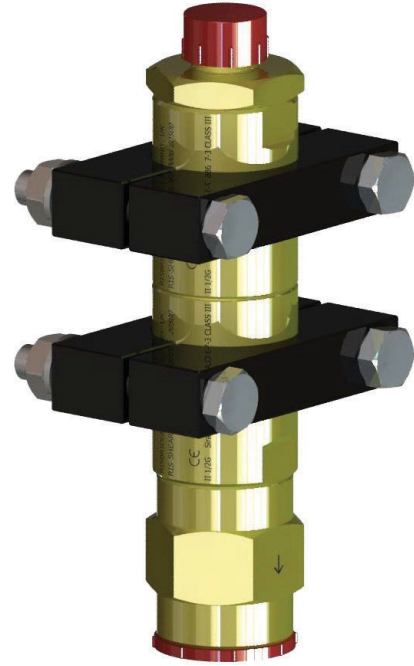

Pt No. RIS-SHEAR-G2

Prevents leakage of saturated vapour onto the forecourt at low level if the dispenser is knocked over or impacted. Also prevents vapour from tank farm returning to forecourt. The integral isolator valve allows maintenance staff to safely replace the main valve once it is damaged.

- Full flow low pressure drop design normally open
- Avoids partial break interference and leak condition with dual opposed piston design
- Seals upstream and downstream on impact
- Cylindrical body fits through and allows sealing with standard membrane seals
- SIRA Certification: II 1/2 G SIRA 06ATEX9258U
- Includes brackets, bolts, isolator valve and instructions
- 3920 N (400 kgF) break force
- Patented design (U<: GB2342709. US: 6.802.332. EU: EP1.222.423.B1)

Materials:

Brass
Anodised Aluminium
Viton A (FKM)
Delrin (polyacetal)
Stainless Steel

Suitable for:

Petroleum Spirit
Diesel

Document Ref:

DATA-RIS-SHEAR-G2-121219

Related Documents:

INS-RIS-SHEAR-G2

Specifications:

Max pressure: +25 Bar

Operating flow range: 0 l/m - 40 l/m

One-way valve: Opens at 20 mbar

Break forces: *

Bending Moment - 420 Nm

* If upper and lower halves rigidly mounted

Operating temperature range:

-20 to +40° C

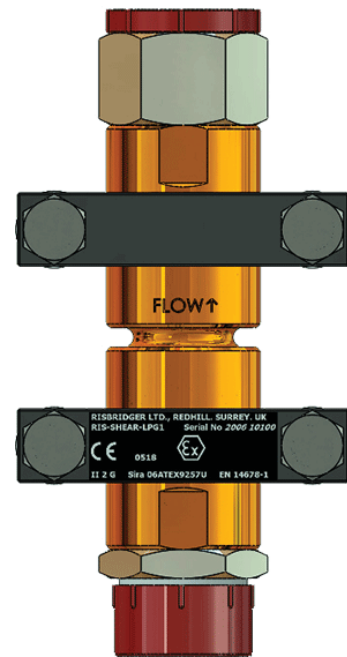

Pt No. RIS-SHEAR-LPG1
with 1" NPT M X F end fittings

RIS-SHEAR-LPG1 shear valves prevent leakage of pressurised product onto the forecourt when the dispenser is knocked over or impacted.

- Full flow low pressure drop design
- Avoids partial break interference and leak condition with displaced ball design
- Seals upstream and downstream on impact
- Consistent 420 Nm bending moment break
- 25 Bar pressure rating with 12:1 Safety factor
- Includes brackets, bolts and instructions
- Non-spark brass construction, nitrile seals
- Optional end fittings and mounting kits available - including isolator valves

SIRA Certified to ATEX and EN 14678-1 II 2 G

Patented design (U<: GB2342709. US: 6.802.332. EU: EP1.222.423.B1)

Materials:

Nitrile
Stainless
Steel
Anodised aluminium clamps
Brass

Suitable for:

Liquid Petroleum Gas product lines
(LPG, GPL, LP Gas, Autogas)

Fittings:

1" NPT female / male
1" BSP female / male

Document Ref:

DATA-RIS-SHEAR-LPG1-160811

Installation Instructions

INS-RIS-SHEAR-LPG

This product family is part of the RIS-FLANGE tanklid fittings range. designed to make Forecourts easier and quicker to install, as well as improving standards, decreasing the probability of leaks, and making testing and maintenance easy and safe.

IMPORTANT NOTE:

The RIS-STOP family of valves are not suitable alternatives for true "shut off valves" and must not be used in continuously pressurised systems.

For more information on available configurations please ask to see our Part Number Matrix.



The only fail-safe, normally closed and testable mechanical valve available. This valve is part of our RIS-STOP range of above and below ground tank overfill prevention valves.

- Lower installation costs, can be assembled into tanks at factory
- Reduce vapour growth, fuel aeration and turbulence with optional Diffuser and Air Transfer Valve
- Normally closed valve, suitable for gravity fill installations
- The ONLY fail-safe mechanical valve available - the ONLY in-situ testable valve available
- High gravity flow rates up to 1025 litres per minute
- The ONLY valve operating effectively at very low flow rates (10 litres / minute)
- Normal operating pressure: 0.3 Bar. Flow operating range: 10 - 1025 litres / minute)
- Operating temperature range: -25°C to +60°C
- SIRA certification: ATEX / SIRA 08ATEX9345 TYPE A1 EN13616:2004
- Manufactured in compliance with European Directive 2014/34/EU

Materials:

Anodised Aluminium
Viton A (FKM)
Delrin (polyacetal)
Stainless Steel

Suitable for:

Petroleum Spirit (including Ethanol Blends up to 90%)
Diesel
Bio Diesel / FAME Blends
AvGas and Jetfuel

Document Ref:

DATA-RIS-STOP-3GF-171113
Maintenance Instructions
MAINT-RIS-STOP-GF
Installation Instructions
INS-FLOAT-KIT
and INS-RIS-STOP-3GF

RIS-STOP-3GF SERIES (GRAVITY FILL) PART NO MATRIX

Risbridger

Quality Engineering Solutions

RIS-STOP-3GF-XXXX

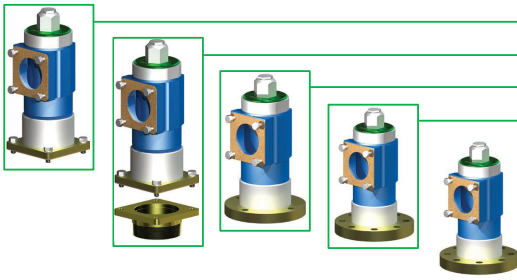

VALVE

4" flanged base.....	F
4" BSPT threaded base.....	1
ANSI 150 flanged base.....	1
ANSI 300 flanged base.....	2
ANSI 150 DN100 flanged base.....	3

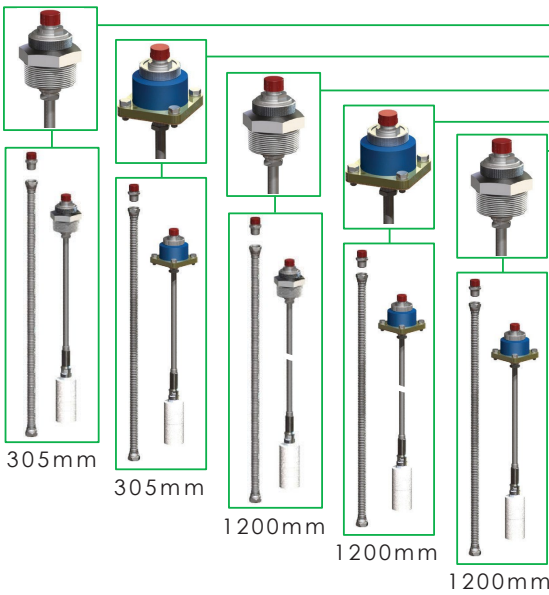

FLOAT

2" BSPT threaded with 305mm float tube.....	1
2" flanged with 305mm float tube.....	2
2" BSPT threaded with 1200mm float tube.....	3
2" flanged with 1200mm float tube.....	4
2" BSPT threaded, 1200mm float tube, 1m hose.....	5

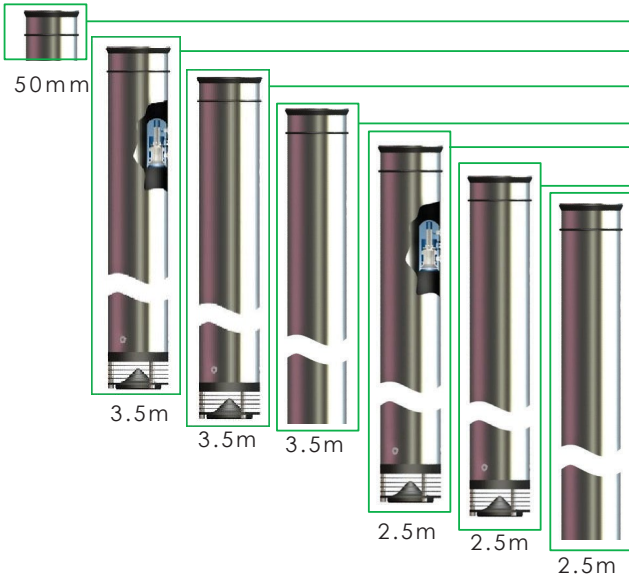

DROP TUBE

None supplied - HOWEVER ONE MUST BE FITTED	0
50mm drop tube stub - * SPECIAL APPLICATIONS ONLY	1
3.5m drop tube with ATV and diffuser.....	2
3.5m drop tube and diffuser.....	3
3.5m drop tube.....	4
2.5m drop tube with ATV and diffuser.....	5
2.5m drop tube and diffuser.....	6
2.5m drop tube.....	7

*** SPECIAL APPLICATIONS ONLY:-**
Where a 'fixed' (i.e. non-removeable) drop tube exists inside the tank, this stub must be included, as a spacer/retainer for internal parts of the valvemodule

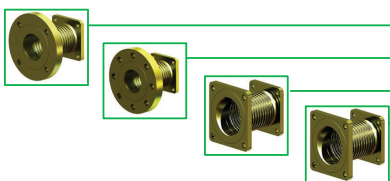

FLEXIBLE CONNECTORS

None.....	0
ANSI 150 to 3" flex.....	1
ANSI 300 to 3" flex.....	2
4" to 3" flex.....	3
3" to 3" flex.....	4

PLEASE NOTE:
IN ORDER FOR THIS PRODUCT TO OPERATE
A FLOAT KIT AND DROP TUBE **MUST** BE FITTED

Your code **RIS-STOP-3GF-**

MATRIX-RIS-STOP-3GF-180723

This product is part of the RIS-FLANGE Tanklid fittings range, designed to make Forecourts easier and quicker to install, as well as improving standards, decreasing the probability of leaks, and making testing and maintenance easy and safe.

Suitable for:

Pressure Fill

Effective at low flow rates

Flow operating range: 10 - 1500 Litres/ minute

Normal operating pressure: +5 Bar

(Tested to 8 Bar)

IMPORTANT NOTE:

The RIS-STOP family of valves are not suitable alternatives for true "Shut off valves" and must not be used in continuously pressurised systems.

For more information on available configurations please ask to see our Part Number Matrix.



Braided flexible connectors available:
PCAT to PCAT and PCAT to ANSI.

The only fail-safe, normally closed and testable mechanical valve available. This valve is part of our RIS-STOP range of above and below ground tank overfill prevention valves.

- Lower installation costs, can be assembled into tanks at factory
- Reduce vapour growth with optional Diffuser and Air Transfer Valve
- Normally closed valve, suitable for pressure fill installations
- The ONLY fail-safe mechanical valve available - the ONLY testable valve available
- High flow rates up to 1500 litres per minute
- The ONLY valve operating effectively at low flow rates (10 litres / minute)
- Operating pressure range: 0.15 - 5 Bar, Flow operating range 10 - 1500 litres / minute)
- Operating temperature range: -25° C to +60° C
- SIRA certification: ATEX / SIRA 07ATEX9165 TYPE A2. EN13616:2004. EN13463-1:2001.
- Manufactured in compliance with European Directive 2014/34/EU

Materials:

Anodised Aluminium
Viton A (FKM)
Delrin (polyacetal)
Stainless Steel
HDPE Closed cell foam

Suitable for:

Petroleum Spirit (including Ethanol Blends up to 90%)
Diesel
Bio Diesel / FAME Blends
AvGas and Jetfuel

Document Ref:

DATA-RIS-STOP-3P-170823
Maintenance Instructions
MAINT-RIS-STOP-3P
Installation Instructions
INS-FLOAT-KIT
and INS-RIS-STOP-3P

**Pt No MATRIX for
RIS-STOP-3P SERIES
(Pressure Fill)**

Risbridger

Quality Engineering Solutions

RIS-STOP-3P-XXXXX

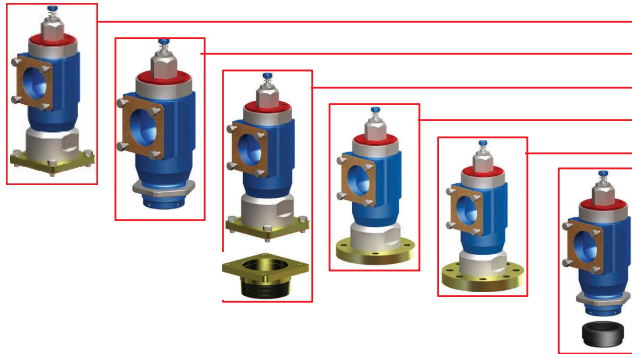

VALVE

4" PCAT flanged base.....	F
3" BSPP threaded base.....	T
4" BSPT threaded base.....	1
3" ANSI 150 flanged base.....	2
3" ANSI 300 flanged base.....	3
3" BSPP threaded base c/w weld socket.....	4

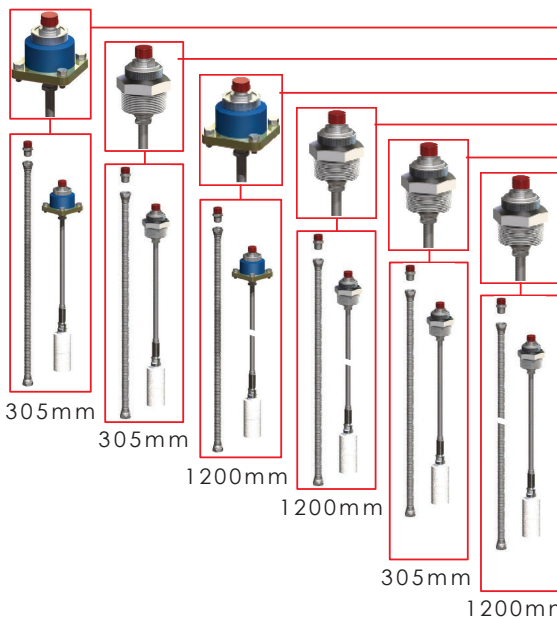

FLOAT

2" flanged with 305mm float tube.....	1
2" BSPT threaded with 305mm float tube.....	2
2" flanged with 1200mm float tube.....	3
2" BSPT threaded with 1200mm float tube.....	4
2" BSPT threaded c/w weld socket and 305mm float tube.....	5
2" BSPT threaded c/w weld socket and 1200mm float tube.....	6



DROP TUBE

None supplied - HOWEVER ONE MUST BE FITTED	0
2m drop tube.....	1
4m drop tube.....	2
2m drop tube and diffuser.....	3
4m drop tube and diffuser.....	4
2m drop tube with ATV and diffuser.....	5
4m drop tube with ATV and diffuser.....	6
3m drop tube with ATV and diffuser.....	7
3m drop tube and diffuser.....	8
3m drop tube.....	9

FLEXIBLE CONNECTORS

None.....	0
3" ANSI 150 to 3" PCAT flex.....	1
3" ANSI 300 to 3" PCAT flex.....	2
4" PCAT to 3" PCAT flex.....	3
3" PCAT to 3" PCAT flex.....	4

INLET ADAPTORS

None.....	0
3" BSP(f) to PCAT 3".....	1

PLEASE NOTE:

IN ORDER FOR THIS PRODUCT TO OPERATE A FLOAT KIT AND DROP TUBE **MUST** BE FITTED



Your code **RIS-STOP-3P-**

MATRIX-RIS-STOP-3P-160405

Specifications:

Flow Rates:

10 - 600 litres per minute

Pressure range:

Normal operating pressure: +5 bar

Maximum pressure: +8 bar

Fluid Viscosity:

Effective with fuel / oil
viscosity of SAE10 or lower

IMPORTANT NOTE:

The RIS-STOP family of valves are not suitable alternatives for true "Shut off valves" and must not be used in continuously pressurised systems.



Pt No. RIS-STOP-2SF-R
(includes 2" weld socket)

Pt No. RIS-STOP-2SF-R-03
(suitable for oils with a viscosity
higher than SAE10)

Suitable for above ground commercial diesel storage installations, and pressure deliveries. It incorporates many proven RIS-STOP features and now includes a more compact 4-bolt flanged inlet on the body allowing greater maximum tank fluid levels.

- Cartridge construction for easy installation and access via the 2" tank lid socket supplied
- Very high flow capacity (50% greater than some competitive products)
- Effective at low flow rates (10-600 l/m) Pressure delivery up to 8 bar maximum
- Various other configurations of this valve are available
- On-site inspection and testing via access cap without pipework dis-assembly
- No dynamic seals - promoting long service life
- Suitable for fuels of SAE10 or lower (other models available for higher viscosity)
- Compatible with all pipe-work brands
- Flexible connectors available: make fitting/servicing easier, remove stress from pipework

Materials:

Anodised Aluminium
Viton A (FKM) Stainless
Steel
HDPE closed cell foam

Suitable for:

Diesel
BioDiesel / FAME Blends

Document Ref:

DATA-RIS-STOP-2SF-R-160308
Installation Instructions
INS-RIS-STOP-2SF-R
Maintenance / Servicing Instructions
MAINT-RIS-STOP-2SF-R

Flow Rates:

10 - 1500 litres per minute

Pressure range:

Normal operating pressure: +5 bar

Maximum pressure: +8 bar

Fluid Viscosity:

Effective with fuel / oil

viscosity of SAE10 or lower

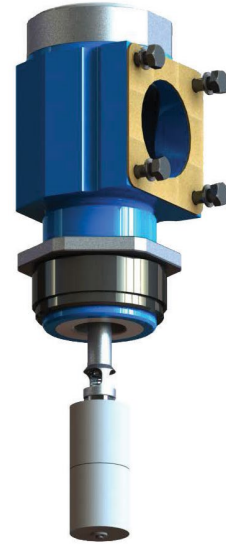
**IMPORTANT NOTE:**

The RIS-STOP family of valves are not suitable alternatives for true "Shut off valves" and must not be used in continuously pressurised systems.

Pt No. RIS-STOP-3SF-PLUS-SOCKET

Available in threaded or flange fit options, the flange fit version comes with a 4" PCAT flange: **Pt No. RIS-STOP-3SF-FLANGE**

Suitable for above ground commercial diesel pressure delivery storage installations.

Incorporates many proven RIS-STOP features and includes a compact 4-bolt flanged inlet on the body allowing greater maximum tank fluid levels.

- Cartridge construction for easy installation and access via the 3" tank lid weld socket supplied
- High flow capacity
- Effective at low flow rates (10-1500 l/m) Pressure delivery up to 8 bar maximum
- On-site inspection and testing via access cap without pipework dis-assembly
- No dynamic seals - promoting long service life
- Suitable for fuels of SAE10 or lower (other models available for higher viscosity)
- Compatible with all pipe-work brands
- Flexible connectors available: make fitting/servicing easier, remove stress from pipework

Materials:

Anodised Aluminium
Viton A (FKM)
Delrin (polyacetal)
Stainless Steel
HDPE closed cell foam

Suitable for:

Diesel
BioDiesel / FAME Blends

Document Ref:

DATA-RIS-STOP-3SF-160308
Installation Instructions
INS-RIS-STOP-3SF

Braided flexible connectors for pressure fill applications.

**Pt No. 5574 (3" ANSI 150 TO 3" PCAT)
Approximately 320mm long**



**Pt No. 5575 (3" ANSI 300 TO 3" PCAT)
Approximately 320mm long**



**Pt No. 5576 (4" PCAT TO 3" PCAT)
Approximately 305mm long**



**Pt No. 5577 (3" PCAT TO 3" PCAT)
Approximately 305mm long**



Materials:

Zinc plated mild steel
Stainless steel

Suitable for:

Petroleum Spirit
(including Ethanol Blends
up to 90%)
Diesel
Bio Diesel / FAME Blends
AvGas and Jetfuel

Document Ref:

DATA-FLEXI

Standard flexible connectors for gravity fill applications

**Pt No. AH5090FL-FL (2" PCAT TO 2" PCAT)
Approximately 90mm long**



**Pt No. AH50160FL-FL (2" PCAT TO 2" PCAT)
Approximately 160mm long**



**Pt No. AH100200FL-FL (4" PCAT TO 4" PCAT)
Approximately 200mm long**



**Pt No. 5295(3" PCAT TO 3" PCAT)
Approximately 150mm long**



Materials:

Zinc plated mild steel
Stainless steel

Suitable for:

Petroleum Spirit
(including Ethanol Blends
up to 90%)
Diesel
Bio Diesel / FAME Blends
AvGas and Jetfuel

Document Ref:

DATA-FLEXI

Standard flexible connectors for gravity fill applications

**Pt No. 5199 (3" ANSI 150 TO 3" PCAT)
Approximately 150mm long**



**Pt No. 5200 (3" ANSI 300 TO 3" PCAT)
Approximately 150mm long**



**Pt No. 5844 (4" PCAT TO 3" PCAT)
Approximately 90mm long**



**Pt No. 5047 (4" PCAT TO 3" PCAT)
Approximately 150mm long**



Materials:

Zinc plated mild steel
Stainless steel

Suitable for:

Petroleum Spirit
(including Ethanol Blends
up to 90%)
Diesel
Bio Diesel / FAME Blends
AvGas and Jetfuel

Document Ref:

DATA-FLEXI

The RIS-FLANGE™ Tank lid System is a flange-based system with blind tapped holes on the tank lid preventing vapour escape into the access chambers. The component's rotation features allow easy fitment without strain on pipe work and without the need for sealants and jointing compounds.

Used in conjunction with our 2" and 4" fittings and adaptors and flexible connectors. The system makes fitting the tank lid components to the pipe-work extremely clean easy and fast. Disassembly for alterations to layouts or for maintenance is also very efficient and easy.

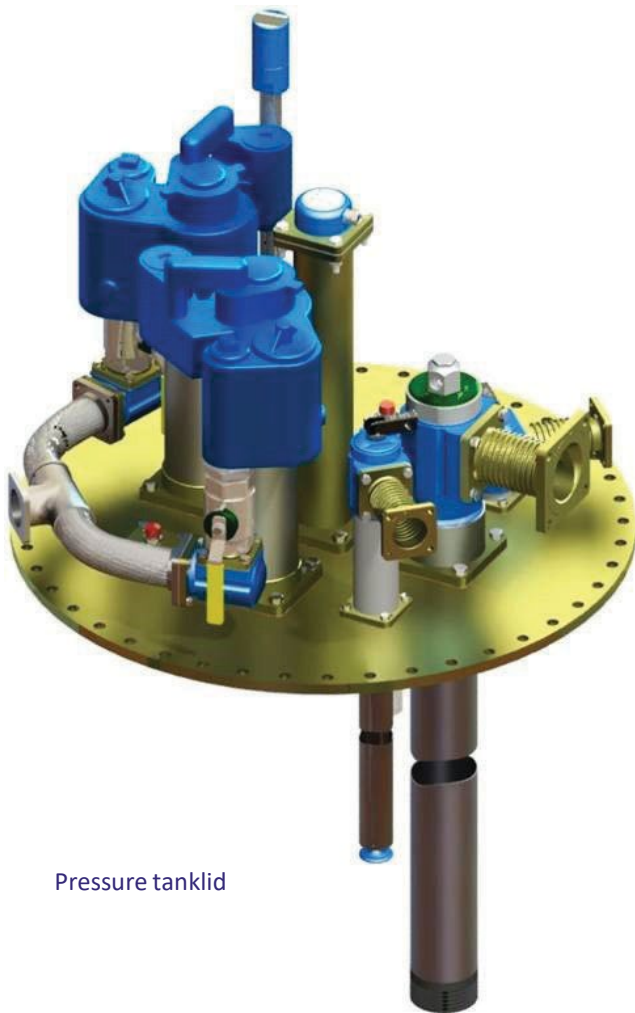

Pressure tanklid



Suction tanklid





RIS-FLANGE2-SO-SUCTION-R2-MK2

2" female threaded base module for use on threaded tank lid ports.

RIS-FLANGE2-SO-VENT-R2-MK2

2" female threaded base module for use on threaded tank lid ports.

AVAILABLE CONFIGURATIONS:

RIS-FLANGE2-SO-SUCTION-15

1.5" female threaded base and outlet for use on threaded tank lid ports. Includes threaded outlet flange.

Also available with 2" base and outlet:

RIS-FLANGE2-SO-SUCTION-20



Flexible connectors available

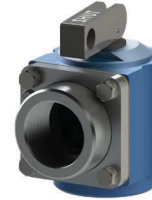

RIS-FLANGE2-SO-VENT-15

1.5" female threaded base and outlet for use on threaded tank lid ports. Includes threaded outlet flange.

Also available with 2" base and outlet:

RIS-FLANGE2-SO-VENT-20

These are part of the RIS-FLANGE Tanklid System. This a comprehensive series of products to populate either suction or pressure system tank lids with high quality, efficient fittings that are easy to install, maintain and test. This system also allows simple disassembly and reconfiguration of layout on tank lids using only hand tools.

- Lower installation costs - can be fitted to tanks in the factory or on site
- Easy to fit to the tank lid, allows 360° rotation of modules to align with pipework entry
- Available with 'Shut-Off' test fitting capability or plain 'elbow' style
- Suitable for use with Bio-Fuel blends up to 90%
- Eliminates leak paths with blind hole tapings on lid
- Compatible with all pipe work brands
- Flexible connectors available: makes fitting easy and remove stress from pipe work

Materials:

Anodised Aluminium
Viton A (FKM)
Delrin (Polyacetal)
Stainless Steel

Suitable for:

Petroleum Spirit (including Ethanol Blends up to 90%)
Diesel
Bio Diesel/FAME Blends

Document Ref:

DATA-RIS-FLANGE2-SO-MODULES-150218

Installation Instructions

INS-RIS-FLANGE2-SUCTION

Maintenance/Service Instructions

MAINT-RIS-FLANGE2-SUCTION

Specifications:

Outlet Flange:

PCAT fittings to suit all pipework systems.

Base Flange:

4 inch flanged base to suit RIS-FLANGE tank lids flanged ports



Pt No. RIS-FLANGE4-TEE-RETRO

Shorter version for lower chambers.

Pt No. RIS-FLANGE4-TEE-MK2

Flanged base to suit RIS-FLANGE Tank lids, and flanged inlet face.

Pt No. RIS-FLANGE4-TEE-R2-MK2

Threaded base to suit traditional tank lids, and flanged inlet face.

Line Testing bung available for both models

Part of the RIS-FLANGE Range of Products, a comprehensive series of products to populate either Suction or Pressure system tank lids with high quality, efficient fittings that are easy to install, maintain and test. This system also allows simple dis-assembly and reconfiguration of layout on tank lids using only hand tools.

- High quality machined bodies, ensure sealing and concentric base and top access.
- Lower installation costs - can be fitted to tanks in the factory or on site.
- Easy to fit to the tank lid, leak free fit to pipework.
- Suitable for use with Bio-Fuel blends up to 90%.
- Flange fitting on inlet (side) port minimises leak paths.
- Assembly includes gasket bolts and integral cage to secure drop tube and OPD.
- Compatible with all pipe-work brands.
- Flexible connectors available: make fitting/servicing easier. removing stress from pipework.

Materials:

Anodised Aluminium
Viton A (FKM) Stainless
Steel

Suitable for:

Petroleum Spirit (including
Ethanol Blends up to 90%)
Diesel
Bio Diesel / FAME Blends

Document Ref:

DATA-RIS-FLANGE4-TEE-MK2-150909

Related Documents

INS-RIS-FLANGE4-TEE

Specifications:

Overall Height: 360mm
Internal Bore: 4"
Top thread: 4" NPT
Rotatable Flange
Plate: 4"

Includes:

Riser, flange plate, flange gasket and bolts and spring washers

Sub-pump riser



Sub-pump shown fitted to Riser and with outlet kit and drain kit (connecting hose not shown)

Pt No. STP-KIT

Sub-pump outlet kit.

Part of the RIS-FLANGE Tanklid System, a comprehensive series of products allowing easy configuration of Pressure (Submersible Pump) system tank lids with high quality, efficient fittings that are easy to install, maintain and test. This system also allows simple dis-assembly and reconfiguration of layout on tank lids using only hand tools.

- Accessory to allow easy fitment of sub-pumps to the tank lid
- Allows 360 degree rotation of modules. aids alignment of bulky sub-pumps
- Suitable for use with Bio-Fuel Blends up to 90%
- Can be fitted to Tanks in the factory or on site
- Flange fitting reduces threaded joints
- Video of full pressure system available from our Website

Materials:

Anodised Aluminium Zinc passivated mild steel

Suitable for:

Petroleum Spirit (including Ethanol Blends up to 90%)
Diesel
Bio Diesel / FAME Blends
AvGas and Jetfuel

Document Ref:

DATA-RIS-FLANGE4-SP-RISER-121213

Installation instructions:

INS-RIS-FLANGE4-SP-RISER

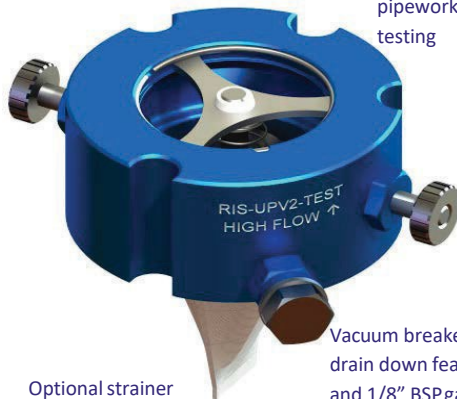

Lock down clamps for pipework isolation and testing

Vacuum breaker / drain down feature and 1/8" BSP gauge point

Optional strainer

Pt No. RIS-UPV2-TEST-HF

Fits both 'Oval' 2 bolt flanges AND 'Triangular' 3 bolt flanges.

Operating flow range:

0 l/m - 130 l/m

Operating Temperature:

- 20 to +90 C

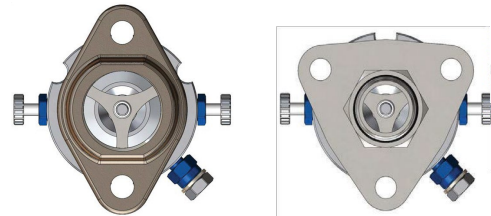

Fits to oval two bolt flange or triangular three bolt flange.

Pressure Loss (kPa) against Flow (l/min)

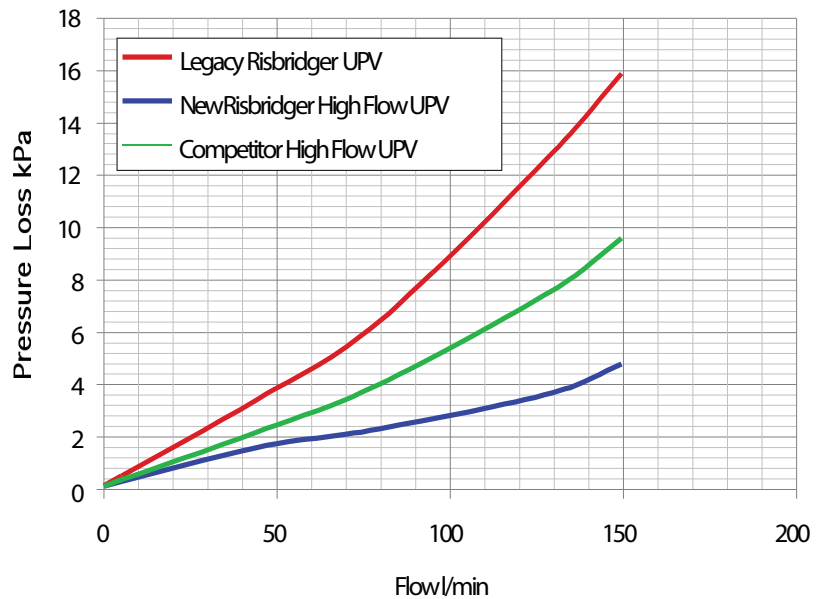

Comparison chart of our new High Flow Under Pump Valve against our old model and a competitors High Flow model.

High flow. low pressure drop. valve allowing flexible fitting arrangements. suitable for fitting to both 2 bolt and 3 bolt flanges:

- High flow capacity: 130 l/m
- Includes vacuum breaker, drain down feature and 1/8" BSP gauge point
- Testable - includes above features AND poppet lock down clamps
- Allows isolation and testing of pipework without disassembly of suction lines
- Compatible with all pipe-work brands
- Flexible connectors available: make fitting/servicing easier, removes pipework stress

Materials: Anodised aluminium Viton A (FKM) Delrin Stainless Steel

Suitable for: Diesel BioDiesel Petroleum Spirit Ethanol Blended Petroleum

Document Ref: DATA-RIS-UPV2-TEST-HF-121129

Installation Instructions
DOC.RIS_UPV_TEST.002.pdf
Maintenance Instructions
MAINT-RIS-UPV

Completely rain proof, these vent caps are part of the INNOVENT range of venting products, which aim to prevent water contamination in tanks, and make it easy to test and maintain crucial venting systems.



AVAILABLE CONFIGURATIONS:

Part No. INNOVENT-2-CAP-FA
Petrol vent cap with integral flame arrestor

Part No. INNOVENT-2-CAP
Diesel vent cap (no gauze)

During our tests we found it impossible to get water into the vent caps. The petrol model with integral flame arrestor, is fully tested and certified to ATEX and EN ISO 16852:2010.

- High Quality machined aluminium bodies, stainless steel flame arrestor element
- Petrol version with flame arrestor to ATEX and EN ISO 16852:2010
- INNOVENT-2-CAP-FA Suitable for use with Bio-Fuel blends up to 90%
- 2" BSP female fitting to attach to vent pipe - can be used with 2" - 3" adaptor

Patent applied for: GB 1505584.1. PCT/GB2016/150913 Certified: ISO 16852 CML 16ATEX6163X

Materials:

Anodised aluminium
Viton
Stainless steel fasteners
Stainless steel flame arrestor

Suitable for:

INNOVENT-2-CAP-FA
Petroleum
INNOVENT-2-CAP
Diesel and heating oils

Document Ref:

DATA-INNOVENT-2-CAP&CAP-FA-161025

Related Documents

INS-INNOVENT-2-CAP-FA

Specifications:

Relief Settings:

8oz per square inch (+35mbar)
0.5 oz per square inch (-2mbar)

Pressure Flow rate: 0-5000l/min

Vacuum flow rate: 0-1500 l/minute

N.B: Must not be used where there is a risk of stabilised burning or where subject to possible impact damage



RIS-VENT2 Plain screw on version



RIS-VENT2QR



RIS-VENT3QR



RIS-VENT2QR-OV

Quick Release Versions Available

A high quality Pressure Vacuum Vent valve for Stage IB and Stage II Vapour Recovery Sites

- Dead weight poppet - provides accurate relief characteristics, retains calibration
- Linear Teflon coated bearing design
- Minimal contact area for low breakout force in sub-zero temperatures
- Drained seat detail prevents ice build up
- Reliable vacuum valve - proven design and materials
- Delrin TM (polyacetal) poppet seat - for best sealing, fuel compatibility and service life
- Environmentally friendly - upward discharge of vapour and minimal operating noise
- Heavy duty construction with anodised finish for long life in extreme environments
- Double layer gauze, seated in groove
- ATEX approved, certificate number SIRA 06ATEX9193X EN16852:2010 /EN13463-1:2009
- 100% tested in Factory. Manufactured in compliance with Article 8 of 94/9/EC

Materials:

Anodised Aluminium
Viton A (FKM)
Delrin (polyacetal)
Stainless Steel

Suitable for:

Petroleum Spirit (including Ethanol Blends up to 90%)
Diesel
Diesel / FAME Blends
AvGas and Jetfuel

Document Ref:

DATA-RIS-VENT-130111
Installation Instructions
INS-RIS-VENT
Maintenance Instructions
MAINT-RIS-VENT
Service Kits available

Specifications:

Relief Settings:

Pressure 1 RPa (10 mbar)

Vacuum -2 RPa (-20 mbar)

Pressure Flow rate: 0-5000 l/minute

Vacuum flow rate: 0-1500 l/minute

N.B: Must not be used where there is a risk of stabilised burning or where subject to possible impact damage



RIS-VENT2QR-AU



RIS-VENT3QR-OV-10
this version has a 10mm orifice in the pressure poppet

A high quality Pressure Vacuum Vent valve for Stage IB and Stage II Vapour Recovery Sites

- Dead weight poppet - provides accurate relief characteristics, retains calibration
- Linear Teflon coated bearing design
- Minimal contact area for low breakout force in sub-zero temperatures
- Drained seat detail prevents ice build up
- Reliable vacuum valve - proven design and materials
- Delrin TM (polyacetal) poppet seat - for best sealing, fuel compatibility and service life
- Environmentally friendly - upward discharge of vapour and minimal operating noise
- Heavy duty construction with anodised finish for long life in extreme environments
- Double layer gauze, seated in groove
- ATEX approved, certificate number SIRA 06ATEX9193X EN16852:2010 /EN13463-1:2009
- 100% tested in Factory. Manufactured in compliance with Article 8 of 94/9/EC

Materials:

Anodised Aluminium
Viton A (FKM)
Delrin (polyacetal)
Stainless Steel

Suitable for:

Petroleum Spirit (including Ethanol Blends up to 90%)
Diesel
Diesel / FAME Blends
AvGas and Jetfuel

Document Ref:

DATA-RIS-VENT-AU-140515
Installation Instructions
INS-RIS-VENT
Maintenance Instructions
MAINT-RIS-VENT
Service Kits available

AVAILABLE CONFIGURATIONS

980VCMK2 - 1.5" or 2" BPS Female

1445VC - 3" BPS Female



Pt No. 98VCMK2

Suitable for use on un-manifolded diesel tanks sites without Stage 1B or Stage 2 Vapour Recovery. These vent assemblies must not be painted or used where they may be subjected to impact damage or to risk of stabilised burning.

FEATURES:

- double layer gauze (stainless steel mesh) seating in retaining grooves
- seating in retaining grooves to prevent vapour by-pass
- internal drain holes to prevent icing up, or water entering vent stack
- positive upward discharge of vapour from tank

Materials:

Aluminium Alloy
Stainless Steel

Tested to:

BS7244.1990 Cat (a) Group IIA

Suitable for:

Diesel Heating
Oil

Document Ref:

DATA-VERTIVENT-CAPS-140807

AVAILABLE CONFIGURATIONS:

Ultra compact Vapour Recovery Adaptor, with retaining chain, cap retaining clip, captive flat Viton A seal and tamper proof operating Key.

Overall height 173mm

The smallest combined VR Adaptor and Flame Arrestor available



Pt No. RIS-FLOW-3-FA-MK2
with optional cap

Retain vapour in your tanks and protect the site vapour connection point with our low-profile Vapour Adaptor. Flame Arrestor and Cap to promote retention of vapour and prevent dangerous vapour around VR connection points. Securely attached high quality flat Viton A seal allows perfect sealing without risk of losing seal.

- Simple cam locking mechanism with tamperproof access key
- Save cost on lost caps - features integral chain and clip
- Extremely low profile adaptor, flame arrestor and cap, overall height 173mm.
- No padlock to seize up
- Integral EN ISO 16852 Flame Arrestor
- Cap includes a captive Viton A flat seal for perfect sealing
- 3" BSP(P) threaded fitting with leather seal

Materials:

Aluminium
Viton A (FKM)
316 Stainless Steel
Low friction coating on valve

Suitable for:

Petroleum Spirit (including Ethanol Blends up to 90%)
Diesel
Bio Diesel / FAME Blends

Document Ref:

DATA-RIS-FLOW-3-FA-MK2-140730

Installation Instructions

INS-RIS-FLOW-3-FA-MK2

Maintenance / Servicing Instructions

MAINT-RIS-FLOW-3-FA-MK2



RIS-DIFFUSER-4

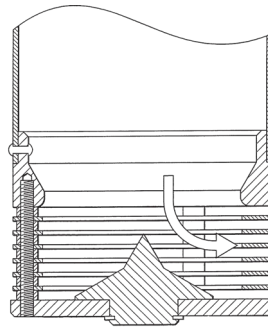

Diffuser cross-section showing laminar flow

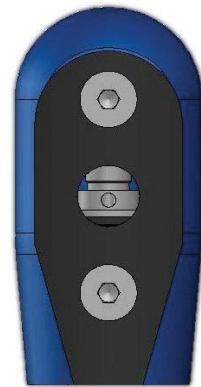

Air Transfer Valve



With a plain drop tube



With a diffuser

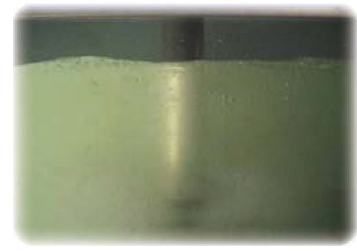

With a Diffuser and ATV

Function - provides horizontal laminar flow of fuel as it is discharged through the drop tube, when used in conjunction with an Air Transfer Valve exceptional reduction of disturbance and vapour growth can be achieved.

- Reduces turbulence, aeration and waves in fuel in storage tanks
- Reduces vapour creation
- Reduces fuel contamination by directing flow away from debris on tank bottom
- Assembles to standard drop tube with rivets, installation template supplied
- Unrestricted flow path through vane stack
- When used with an Air Transfer Valve (ATV) substantial vapour savings can be achieved

Materials:

Anodised Aluminium
Stainless Steel
Brass

Suitable for:

Petroleum Spirit (including Ethanol Blends up to 90%)
Diesel
Bio Diesel / FAME Blends
AvGas and Jetfuel

Document Ref:

DATA-CALM-FUEL-DELIVERIES-140901

Installation Instructions:

INS-RIS-DIFFUSER-3
INS-RIS-DIFFUSER-4



Pt No. RIS-DIFFUSER-3



Pt No. RIS-DIFFUSER-4

Related Product:

DATA-SUCTION-DEFLECTOR-4171
Suction plate deflector shown included in a modular suction assembly (above left) and unassembled (above right)

AVAILABLE CONFIGURATIONS

RIS-DIFFUSER-3 - For 3" Aluminium drop tubes
RIS-DIFFUSER-4 - For 4" Aluminium droptubes

DIMENSIONS

RIS-DIFFUSER-3: 75mm (h) x 82.5mm (w)
RIS-DIFFUSER-4: 92mm (h) x 94.6mm (w)

Designed to prevent debris from being disturbed in the storage tank, and then being dispensed to vehicles on the forecourt. The Diffuser and Air Transfer Valve when used together produce calmer tank contents, less aeration and turbulence: Calmer deliveries - less vapour growth and foaming

- Reduce the amount of debris stirred up during deliveries
- Reduce the changing or cleaning of dispenser and check valve filters
- For best results use with Air Transfer Valve (RIS-ATV) and SUCTION DEFLECTOR
- RIS-DIFFUSER and Air Transfer Valve (RIS-ATV) prevent aeration and vapour growth

Materials:

Anodised Aluminium
Stainless Steel
Brass

Suitable for:

Petroleum Spirit (including Ethanol Blends up to 90%)
Diesel
Bio Diesel / FAME Blends
AvGas and Jetfuel

Document Ref:

DATA-RIS-DIFFUSER-140520

Installation Instructions:

INS-RIS-DIFFUSER-3
INS-RIS-DIFFUSER-4

The Air Transfer valve allows the slug of air trapped in the fill line between the delivery tanker and submerged drop tube exit to escape into the tank ullage, instead of being pressurised and forced through the stored product in the tank.

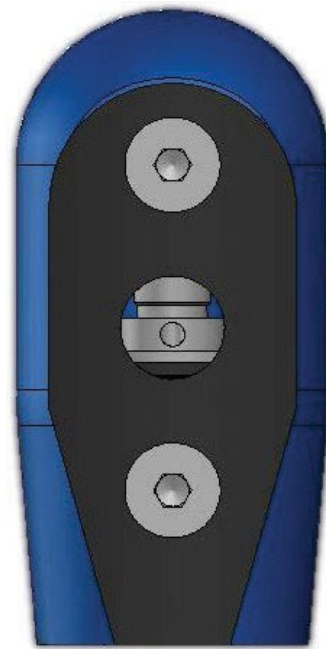

Pt No. RIS-ATV

ADVANTAGES:

- Reduced creation of vapour
- Reduces turbulence of fuel in the storage tank
- Faster delivery cycle
- Reduced risk of fill line lock-ups and blow-backs
- Prevents aeration of suction lines and loss of pump prime

The Patented RIS-ATV can be easily installed on site, with new or existing removable drop tubes. RIS-ATV valves are compatible with both RIS-STOP and other makes of Overfill Prevention Devices.

Materials:

Anodised Aluminium
Stainless Steel
Viton

Suitable for:

Petroleum Spirit (including
Ethanol Blends up to 90%)
Diesel
Bio Diesel / FAME Blends
AvGas and Jetfuel

Document Ref:

DATA-RIS-ATV-140812



Pt No. RIS-DIFFUSER-4

Fits to fill tube to calm deliveries into.



Suction Deflector 4171



Shown fitted to a suction pipe

A one-piece assembly fitted to the bottom of suction tubes with stainless steel rivets to prevent debris from being pulled from tank bottom by the suction system

This product is a standard part of the RIS-FLANGE Tanklid fittings range. and is fitted to our standard Suction Modules. Can also be retrofitted to existing suction pipes. providing access to them is available. Designed to prevent the debris on tank bottoms from being pulled directly into the suction system, protecting dispenser pumps and ancillary check valves etc.

- Reduce the number of debris pulled from the tank by the suction system
- Reduce the changing or cleaning of dispenser and check valve filters
- For best results use with RIS-DIFFUSER and Air Transfer Valve (RIS-ATV)
- RIS-DIFFUSER and Air Transfer Valve (RIS-ATV) prevent aeration and turbulence in the tank during tanker deliveries.

Materials:

Anodised Aluminium

Suitable for:

Petroleum Spirit (including Ethanol Blends up to 90%)
Diesel
Bio Diesel / FAME Blends
AvGas and Jetfuel

Document Ref:

DATA-SUCTION-DEFLECTOR-4171-121210

AVAILABLE CONFIGURATIONS:

5 port Do-nuts:

Pt No. RIS-DONUT-5-20-25

Body diameter 99mm
3 x M20 ports, 2 x M25 ports
(without glands)

Pt No. RIS-DONUT-5-20

Body diameter 99mm 5
x M20 ports (without
glands)



RIS-DONUT-9-20 shown above
with optional cable glands

6 port Do-nuts:

Pt No. RIS-DONUT-6-20-25

Body diameter 99mm
3 x M20 ports, 3 x M25 ports
(without glands)

12 port Do-nuts:

Pt No. RIS-DONUT-133- 12-20

Body diameter 133mm
12 x M20 ports (without
glands)



RIS-DONUT-5-20 shown above

Designed to prevent escape of vapour from access chambers into cable ducts. whilst making routing of cables neat and easy with the use of IP68 rated cable glands. M20/M25 threaded ports for IP rated cable glands.

- Simple to use and easy to seal cable gland 'Do-nut'
- Prevents vapour escaping into cable ducts
- 99mm diameter models available
- 133mm diameter model available with 12 x M20 ports
- Available with integral IP68 rated gland fittings on request
- To be used with proprietary cable duct seals
- Complies with Directive 94/9/EC

Materials:

Anodised aluminium

Suitable for:

IP68 rated gland fittings

Fittings:

(according to model - see above)
M20
M25

Document Ref:

DATA-CABLE-GLAND-DONUT-140807

Pt No. RIS-PRESSURE-DIP-KEY (red key only)



Pt No. RIS-PRESSURE-DIPX1

Assembled with a dip-rod (shown)
(dip-rod not supplied by Risbridger) and
special tamper proof key (shown)

Available configurations:

2" RIS-FLANGE:

Swivel base to allow easy alignment - fits to 2"
flange port on RIS-FLANGE lids (or to 4" port with
use of 4 to 2 Adaptor plate)

THREADED VERSION:

RIS-FLANGE thread base adaptor



Pt No. RIS-PRESSURE-DIP-FA
shown with upper and lower
dip tubes (not supplied by
Risbridger)

Part of the RIS-FLANGE Tanklid System or configured for standard threaded tank lids, this item is designed to allow dip testing for water contamination of tanks on Stage II Vapour Recovery sites. It is specifically designed to prevent release of high volumes of vapour to the atmosphere by means of a liquid sealed dipping tube.

- Two level position prevents the dip rod from resting on tank floor when not in use
- Secure locking key prevents un-authorized use or access to the dip cap assembly
- Suitable for use with Bio-Fuel Blends up to 90%
- Can be fitted to any RIS-FLANGE tank lids or standard threaded lids
- Dip rod drilling jig available for installation contractors

Materials:

Anodised Aluminium
Viton A (FKM) Stainless
Steel

Suitable for:

Petroleum Spirit (including
Ethanol Blends up to 90%)
Diesel
Bio Diesel / FAME Blends

Document Ref:

DATA-RIS-PRESSURE-DIP-150909
Maintenance Instructions
MAINT-RIS-PRESSURE-DIP
Installation Instructions
INS-PRESSURE-DIP

RIS-RISER-3F-MK2 (shown on right)

- Flanged top, flanged bottom
- RIS-RISER height (less cap) is 500mm flange face to flange face

RIS-RISER-3F-BSP-MK2

- Flanged top, threaded bottom
- 3" BSPT threaded base, which allows fitment to traditional threaded port tank lids

RIS-RISER-3T

- Flanged top, threaded adaptor
- RIS-RISER cap assembly to fit to your own riser, with 3" BSPP female fitting

RIS-RISER-R4-3F

- Flanged top, flanged bottom, plus 4" BSPT retrofit male fitting
- RIS-RISER height (less cap) is 500mm flange face to flange face



- These units are designed to mount electric level cartridges of up to 80mm OD, by other manufacturers, directly to a RIS-FLANGE™ Tanklid System
- The flanged swivel cap assembly allows the cable to exit the RIS-RISER in a horizontal plane to any required orientation
- The ATEX approved and IP68 rated metal cable gland supplied comes with a standard 4.0 – 8.0mm bush

Materials:

Anodised Aluminium
Zinc Passivated Mild Steel
Stainless Steel

Suitable for:

Petroleum Spirit (including Ethanol Blends up to 90%)
Diesel
Bio Diesel / FAME Blends
AvGas and Jetfuel

Document Ref:

DATA-RIS-RISER-151012

Installation instructions:

INS-RIS-RISER-151012



**Pt No. 4921 (TEST TOOL FOR
RIS-STOP-3P & 3GF OPV'S)**

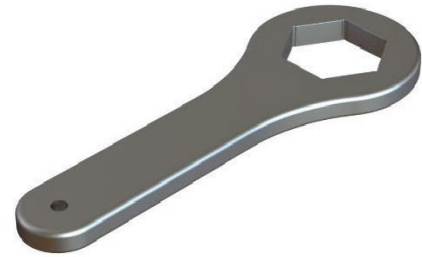

**Pt No. 5216
(4" TEE CAP WRENCH)**



**Pt No. 4921
(2" FLANGE WRENCH)**



**Pt No. 5373
(3P & 3GF CARTRIDGE TOOL)**

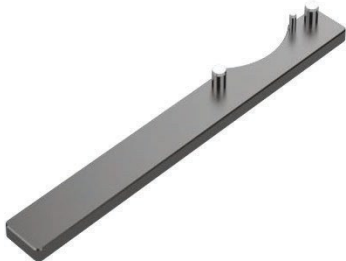

**Pt No. 4496
(4" FLANGE WRENCH)**



**Pt No. 5340
(RIS-FLANGE2 CAP TOOL)**

All Risbridger tools are supplied with a full set of instructions including a step-by-step pictorial guide.

Risbridger

Quality Engineering Solutions

Design innovation
Sound engineering
Integrity
Quality

for over



FORECOURT PRODUCT DISTRIBUTORS:

UK and Eire

PFS Fueltec

Unit 2-3 Wheaton Court
Eastern Industrial Estate
Wheaton Road, Witham
Essex, CM8 3UJ

UKTel: +44 (0)1376 535260

Fax: +44 (0)1376 535268

Contact: alex.Boudry@pfsfueltec.com

Website: www.pfsfueltec.com

France, Belgium, Netherlands, Luxembourg and North Africa

CGH Belgium NV

Rijksweg 10 C
B-2880 BORNEM
Belgium

Tel: +32 (0)3 459 80 76

Fax: +32 (0)3 459 80 82

Contact: Pieter Rebry

Website: www.cghbelgium.com

Malaysia

Zapfventile Fuelling Solutions SDN BDH

No: 35 Jalan BulanBP U5/BP
Bandar Pinggiran Subang
Subang 40150
Shah Alam
Malaysia.

Tel +603 (0) 5889 9094

Contact : Eric Koh erickoh@zapfs.com.my

Mobile No: +60172425665

Netherlands

TSE Online

De Bleek 40
7468 DL Enter
Netherlands

Tel: +31 355 256 976

Contact: martijn.noordink@tseonline.nl

Website: www.tseonline.nl

Spain and Portugal

Marjop S.L.

Polígono industrial Mejorada
c/ Aragon 84
28840 Mejorada del Campo
Madrid
Spain

Tel: +34 91 668 00 90

Fax: +34 91 668 20 98

Contact: Joaquin Ortiz

Email: joaquin@tavicce-marjop.com

Website: www.tavicce-marjop.com



Contact

+44 (0) 1737 372 680

info@risbridger.com

www.risbridger.com

Follow Us



Risbridger Ltd

25 Trowers Way
Holmethorpe Ind Est
Redhill
Surrey
RH1 2LH