

Rain Cowl:

- ATEX approved flame arrestor
- Rain proof cowl
- Zero maintenance (self cleaning)
- O-ring seal to vent pipe – no need for sealant

Low Level Pressure Vacuum Valve

- Low cost
- Easily maintained
- No need for working at height
- Cost effective solution
- Pressure Flow rate 0-5000 l/min
- Vacuum flow rate 0-1500 l/minute
- +35mbar
- -2mbar

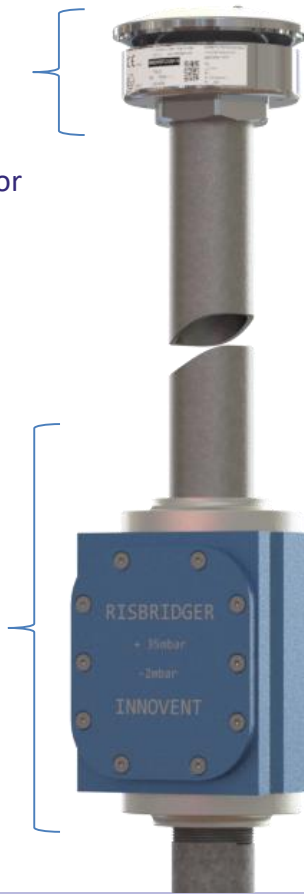

INNOVENT-MK3 is a modular system:

The following can be added on:

- Condensate collector – to collect any condensation in the riser pipe between the PVV and cowl – self draining
- Minimesse™ test ports
- Ball valve can be installed below PVV to assist with routine maintenance
- 2" Pcat flanges available for flanged manifolds

Maintenance:

- Easily maintained at low level manifold
- Cost effectively maintained using cartridge replacement kit

Part numbers:

- **INNOVENT MK3 (Standard PV Valve)**
- **INNOVENT MK3–OV (Orifice PV Valve)**

A high quality Pressure Vacuum Vent valve for Stage IB and Stage II Vapour Recovery Sites

- Dead weight poppet - provides accurate relief characteristics, retains calibration
- Linear Teflon coated bearing design
- Minimal contact area for low breakout force in sub-zero temperatures
- Reliable vacuum valve - proven design and materials
- Delrin™ (polyacetal) poppet seat - for best sealing, fuel compatibility and service life
- Environmentally friendly - upward discharge of vapour and minimal operating noise
- Heavy duty construction with anodised finish for long life in extreme environments
- Double layer gauze, seated in groove
- ATEX approved flame arrestor (Certificate Number CML 16ATEX6163X EN ISO 16852:2010)
- 100% tested in factory

Materials:

Anodised Aluminium
Viton A (FKM)
Delrin (polyacetal)
Stainless Steel

Suitable for:

Petroleum Spirit
(including Ethanol blends up to 90%)

Document Ref:

DATA-INNOVENT-MK3
Installation Instructions
INS-INNOVENT-MK3
Maintenance Instructions
MAINT-INNOVENT-MK3

Version 190924