

This 7 Series model fits a 1 US quart factory packed round container and comprises the following parts:

- 54 inch clear conductive PVC hose
- 1870 coupling (OMP2506-3 equivalent)
- Stowage point for protection of 1870 coupling
- 1997 sight-glass/air bleed valve
- 1600 filter element (beta 200 = 4.6 micron)
- Stability base
- 'ENGINE OIL' fluid identification plate



(Assembly shown with packing tube in place of oil can)

Obsolete drawing reference: UZ/7/1606/5 and UZ/7/1826

Rolls Royce part number: 3409536 (Trent 700 engine)

The special 1600 filter element (beta 200 = 4.6 micron, in accordance with ISO 16889) fitted to Risbridger equipment dispenses filtered fluids to a cleanliness level of DefStan 05/42 400F or ISO 4406 Class 17/15/12.

**Improve reliability and service life of your aircraft engines and components. Using our quick disconnect couplings and high level filtration you will protect the fluid**

- Cans of oil are fitted to the pump before opening, preventing contamination of contents
- Integral can opener and suction pipe
- 'Stowage nose' for 1870 couplings - keeps hose tidy, prevents damage to coupling
- Available for many fluid/aircraft/system types
- Integral 'No Filter - No Flow' safety valve
- Stability base prevents toggle straps collapsing the can and improves sealing

Applicable to the following aircraft models:

**Airbus** A300, A310, A318, A319, A320, A321, A330, A340, A350 and A380.

**Boeing** 727, 737, 747, 757, 767, 777 and 787. **Bombardier** Challenger 601, 604, 605, 850, Global Express 5000, 6000, 7000, 8000, CRJ100, CRJ200, CRJ700, CRJ900 and CRJ1000.

**COMAC** ARJ21. **Embraer** ERJ170, ERJ175, ERJ190 and ERJ195. **Gulfstream** G200, 300, 450, 550, 650, II, III, IV and V. **McDonnell Douglas** DC-8, DC-9, DC-10, MD11 and MD80.

### Materials:

Anodised aluminium  
Acetal-homopolymer  
Zinc plated steel  
Stainless steel  
Brass

### Suitable for:

Engine oils  
(clear conductive PVC hoses)

### Document Ref:

DATA-7011-160629

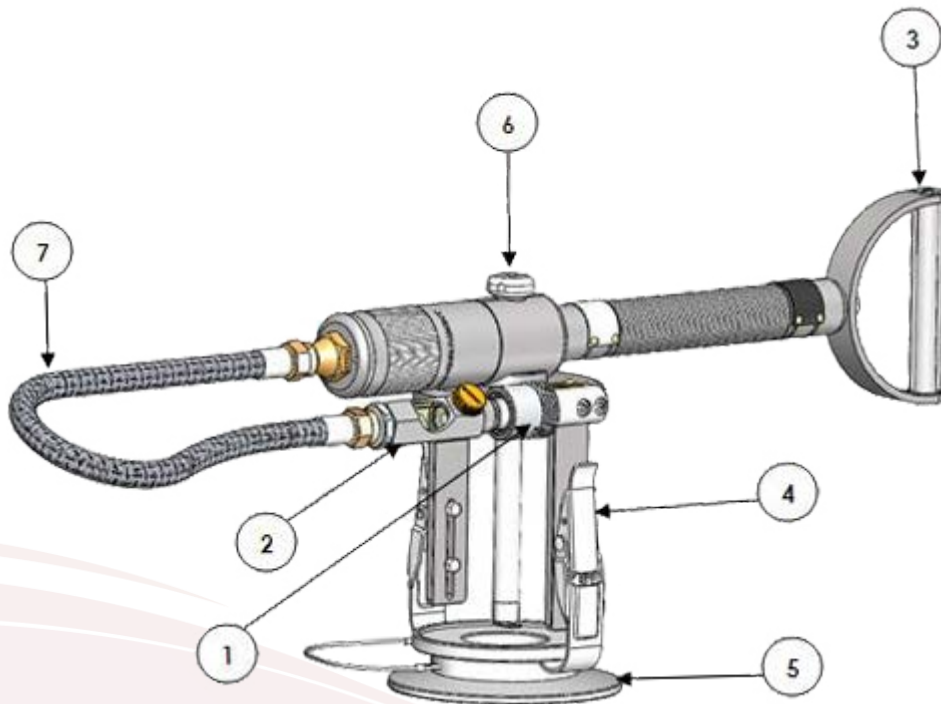

### SPARES PART NUMBERS:

Item No	Risbridger Stock Code	Description
1	1870COUPLING	Coupling (OMP2506-3 Equivalent) – Viton™ Seals
	1871	Dust Plug (OMP2506-5 Equivalent) – Viton™ Seals – Not Shown
2	1997	Sight Glass/Bleed Valve Assembly
	1600FILTER	Filter Element (Beta 200 = 4.6 Micron) – Viton™ Seals – Not Shown
3	UZ7/1	Piston Rod, Handle and Cylinder Assembly
	UZ7/5	Seal Kit c/w Valve (Non Shut-Off and Shut-Off T/P) – Not Shown
4	786/9	Toggles and Straps Only
5	STABILITY-BASE	Stability Base Kit for 7 Series Pumps
6	UZ/E/06	Suction Pipe and Knob (Quart)
7	PC852	36in Clear Conductive PVC Hose
	PC853	54in Clear Conductive PVC Hose
	PC851	72in Clear Conductive PVC Hose

#### Pump Volume Rating:

1 US quart - 28 strokes  
1 litre - 30 strokes  
2 cu in/33cc/33ml - 1 stroke

#### Temperature Range:

Engine Oil pumps with clear hose:  
-20°C to +65°C

Mineral Hydraulic pumps with  
clear/black hose: -20°C to +65°C

#### Manufacturers NCAGE Code:

K6057